

RoboCell

VERSION 7 FOR

SCORBOT-ER 4U

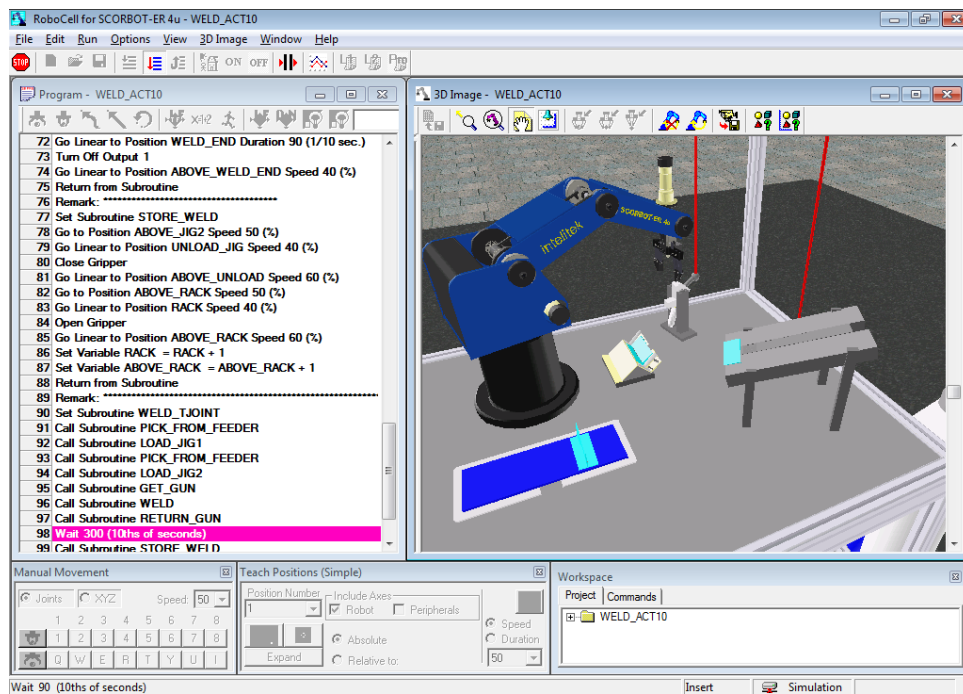

USER MANUAL
Catalog #100346 Rev. H

intelitek ▶▶



Copyright © 2016 Intelitek Inc.

Tel: (603) 625-8600

RoboCell User Manual

Fax: (603) 437-2137

Cat.# 100346 Rev. H

March 2016

website: <http://www.intelitek.com>

email: info@intelitek.com

All rights reserved. No part of this publication may be stored in a retrieval system, or reproduced in any way, including but not limited to photocopy, photography, magnetic or other recording, without the prior agreement and written permission of the publisher. Program listings may be entered, stored and executed in a computer system, but not reproduced for publication.

Every effort has been made to make this book as complete and accurate as possible. However, no warranty of suitability, purpose, or fitness is made or implied. Intelitek is not liable or responsible to any person or entity for loss or damage in connection with or stemming from the use of the software, hardware and/or the information contained in this publication.

Intelitek bears no responsibility for errors that may appear in this publication and retains the right to make changes to the software, hardware and manual without prior notice.



Table of Contents

1.	Introducing RoboCell	1
2.	Starting RoboCell	3
2.1.	System Requirements.....	3
2.2.	Software Licensing.....	3
2.3.	Installing the Software.....	3
2.4.	RoboCell Utilities	6
2.4.1.	3D Simulation Software Demos.....	6
2.4.2.	Uninstalling RoboCell	7
2.5.	Quitting the Software	7
3.	Graphic Interface	9
3.1.	Rotate.....	9
3.2.	Zoom	9
3.3.	Angle.....	10
3.4.	Brightness.....	10
4.	CellSetup	11
4.1.	Opening CellSetup	11
4.2.	CellSetup Window	12
4.3.	File Menu.....	13
4.4.	Edit Menu	14
4.5.	View Menu	15
4.6.	Help Menu.....	18
4.7.	Objects	18
4.7.1.	Object Placement.....	18
4.7.2.	Object Configuration	19
4.7.3.	Object Properties Menu	19
4.8.	New Objects Menu	20
4.8.1.	Robots	21
4.8.2.	Peripheral Axes	23
4.8.3.	I/O Devices	24
4.8.4.	Storage Devices	27
4.8.5.	Machines.....	30
4.8.6.	Welding Tools.....	32
4.8.7.	Welding Materials	34

4.8.8.	General.....	36
4.8.9.	Materials	37
4.8.10.	User Objects.....	39
4.8.11.	Designing User Parts and Objects	40
5.	Working in RoboCell	43
5.1.	RoboCell Menus	43
5.1.1.	File Menu	44
5.1.2.	Edit Menu.....	45
5.1.3.	Run Menu.....	45
5.1.4.	Options Menu	46
5.1.5.	View Menu	46
5.1.6.	3D Image Menu.....	46
5.1.7.	Window Menu.....	46
5.2.	Graphic Display Module	46
5.2.1.	3D Image Menu & Toolbar	47
6.	Cell Operation	51
6.1.	Robot Manual Manipulation	51
6.2.	Machine Operation	51
6.3.	Send Robot Commands	51
6.4.	Gripper	53
6.4.1.	Grasping Objects	53
6.4.2.	Releasing Objects	53
6.5.	Impact Detection	53
6.6.	Defining Positions	54
6.6.1.	Recording Position #1.....	54
6.6.2.	Recording Position #2.....	54
6.6.3.	Teaching Position	55
6.6.4.	Fine-tuning a Position.....	55
6.7.	Program Execution	55
7.	Welding Features	57
7.1.	Introducing Welding Features	57
7.2.	Welding Table Configuration	59
7.3.	Welding Machine Properties	60
7.4.	Welding Tools.....	62
7.4.1.	Gun Stand.....	62
7.4.2.	Welding Jig A (T-Joint)	63
7.4.3.	Welding Jig B	63
7.5.	Welding Materials	64



- 7.5.1. Plate 64
- 7.5.2. Metal Cube 65
- 7.6. Additional Welding Features 66
 - 7.6.1. Advanced Send Robot Commands 66
 - 7.6.2. Welding Booth Doors 67
 - 7.6.3. Welder 67
 - 7.6.4. Welding Parameters 68
- 7.7. Welding Process 69
 - 7.7.1. Welding Gun Operation 69
 - 7.7.2. Weld Temperature 69
 - 7.7.3. Welded Part 69
- 7.8. Weld Analysis 69
- 7.9. Replicating Real and Simulated Cells 70
 - 7.9.1. From Simulation to Practice 70
 - 7.9.2. From Practice to Simulation 71
- 8. Sample RoboCell Projects 73
 - 8.1. 3D Project Descriptions 73
- 9. Troubleshooting 75

1. Introducing RoboCell

RoboCell is a software package that integrates four components:

- SCORBASE, a full-featured robotics control software package, which provides a user-friendly tool for robot programming and operation
- A Graphic Display module that provides 3D simulation of the robot and other devices in a virtual workcell
- CellSetup, which allows a user to create a new virtual robotic workcell, or modify an existing workcell
- 3D Simulation Software Demo to demonstrate RoboCell's capabilities

This manual covers all features and operation of the Graphic Display and CellSetup modules. It provides support for all current versions of RoboCell.

SCORBASE menus and commands are described in the SCORBASE User Manual.

2. Starting RoboCell

The following sections describe the steps involved in starting RoboCell.

2.1. SYSTEM REQUIREMENTS

For best performance, the following system is recommended:

- Intel Core i5 2400 GHz 2400 GHz or higher, equipped with CD drive
- At least 1GB RAM (4 GB for Windows 7 and higher)
- A hard drive with at least 200 MB of free disk space
- A mouse
- USB port
- Windows XP/7/8/8.1/10

Note: Your operating system might have additional hardware requirements.

2.2. SOFTWARE LICENSING

The RoboCell software is protected by a licensing agreement. Full details on the Intelitek software licensing are provided in the Intelitek Software Licensing Guide.

2.3. INSTALLING THE SOFTWARE

The RoboCell software is supplied on a CD which also contains SCORBASE. Close any applications that are open before proceeding with the installation procedures. If you are about to reinstall the software, or install a newer version to an existing RoboCell directory, it is recommended that you back up any existing user-created files before you begin the installation. It is also recommended that you remove the previous RoboCell version for Windows installation using the software's Uninstall utility (For more information on uninstalling RoboCell, see 2.4.2 Uninstalling RoboCell on page 7).

To install SCORBASE:

1. Insert the CD into the CD-ROM drive to start the installation procedure.
2. If the installation procedure does not start, either:
 - a. From the Windows task bar, click **Start | Run** and type D:Setup (where D: is your CD drive), or
 - b. Using Windows Explorer, explore the CD drive and click  Setup.

3. Wait until the Welcome window is displayed.

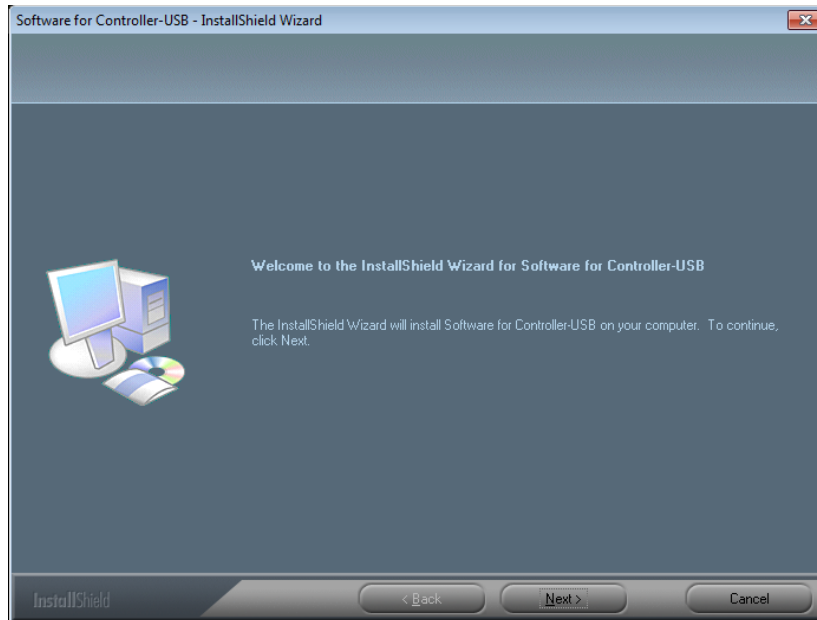

4. Click **Next**. The License Agreement window is displayed.

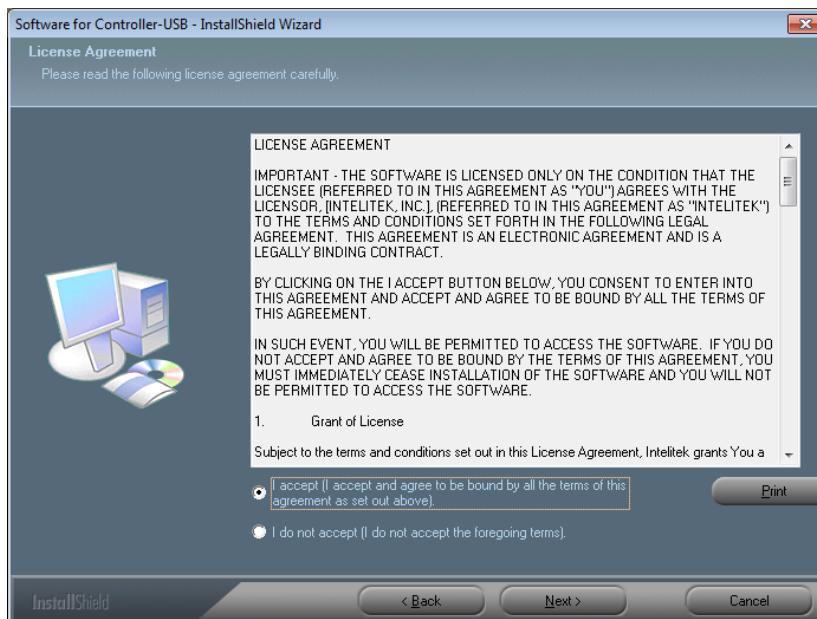

5. Review the Intelitek software license agreement. You must accept the terms of this agreement in order to proceed with the installation. To accept, select **Yes**. The Software Selection Window is displayed.

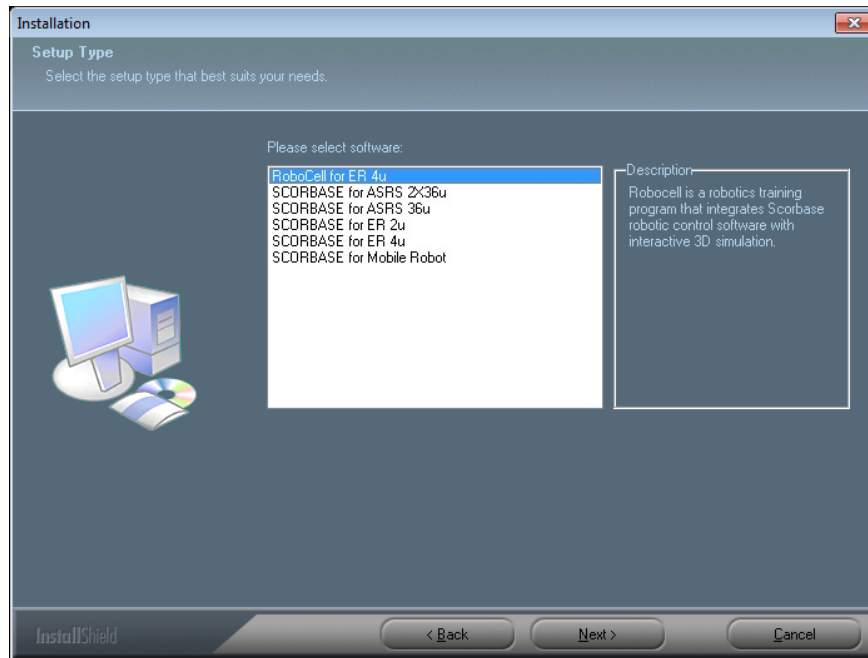

6. Select **RoboCell for ER 4u**. The robot that you select becomes the default robot while you are working in RoboCell, although you can choose to open a new project and work with a different robot. See the Hardware Setup option in the Options Menu.

Click **Next**. The Setup Type window is displayed.

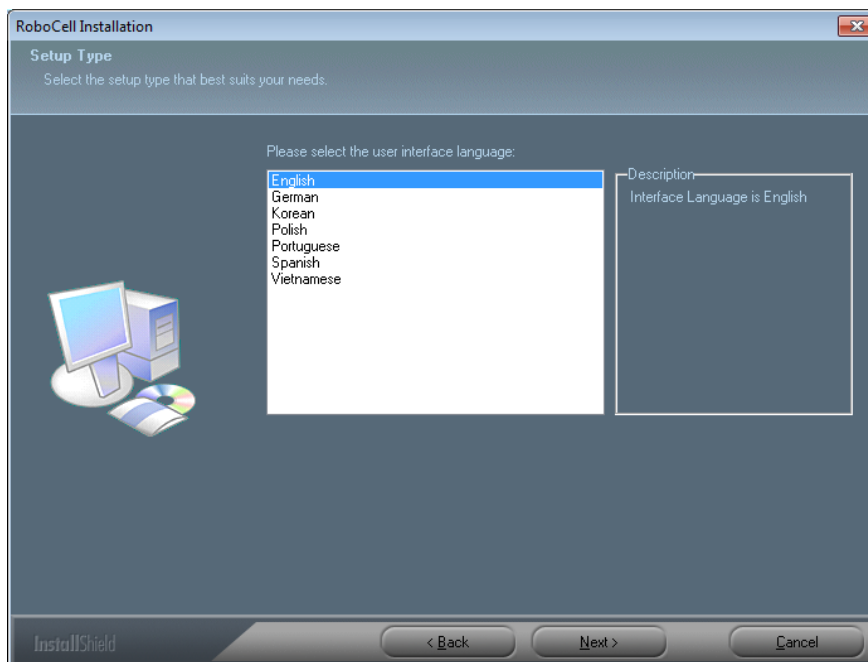

7. Select the desired language and click **Next**. The Choose Destination Location window is displayed.

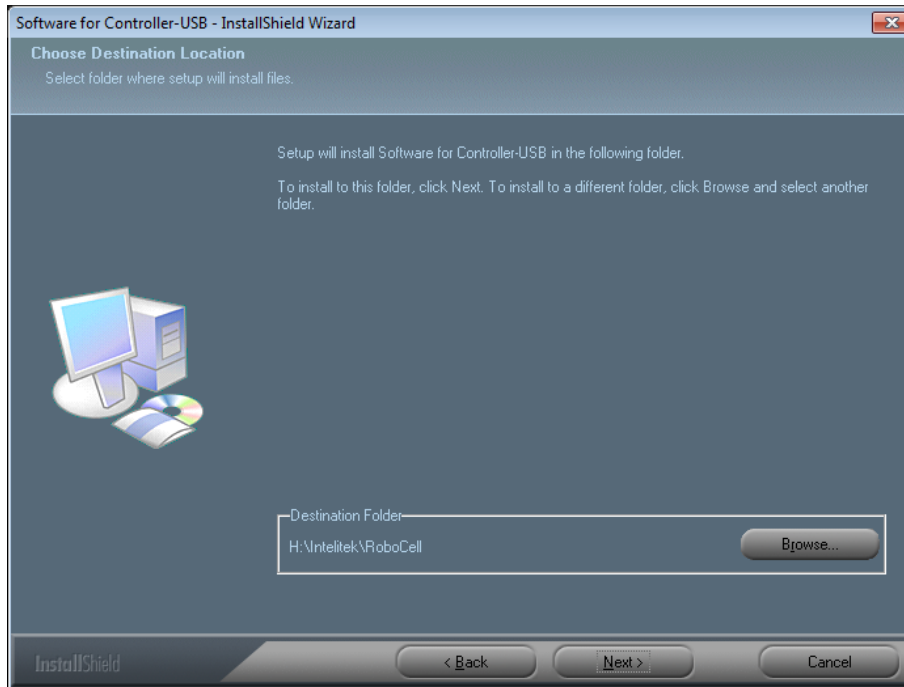

8. The default destination folder for the files is: \Intelitek\RoboCell.

Click **Next** to accept the default, or click **Browse** to select another folder, and then click **Next** to display the Select Program Folder window.

9. Click **Next** to complete the installation procedure.

2.4. ROBOCELL UTILITIES

These utilities are available from the RoboCell group:

- CellSetup
- 3D Simulation Software Demos
- Uninstall

2.4.1. 3D Simulation Software Demos

Demonstration files included with the software allow you to observe the capabilities of RoboCell. To run these demo files, perform the following:

1. Activate the demos by selecting **Start | Programs | RoboCell | 3DSimulation Software Demos**. The default demo opens and starts automatically.

2. To view another demo file, select **File | Open**, or click the Open  icon.



3. Select the desired *.DMO file from those listed in the Open window. The program starts automatically.
4. To stop a demo, select **File | Stop**.
5. Use the Menu options or Toolbar icons to navigate in the virtual cell. See Chapter 4 CellSetup on page 11 for full details.
6. To exit the Demos utility, select **File | Exit**.

2.4.2. Uninstalling RoboCell

To uninstall RoboCell:

1. From the RoboCell program group, select **Uninstall**.
2. Follow the instructions which are displayed on the screen.

The Intelitek Software Licensing Guide provides full details on the procedures for protecting your license, transferring the license from one PC to another, and returning the license to Intelitek for retrieval at a later time.

2.5. QUITTING THE SOFTWARE

To close RoboCell (or its components), perform any of the following:

- From the menu bar, select **File | Exit**.
- Click the Close box in the SCORBASE Title Bar.
- Press **[Alt]+F4**.

3. Graphic Interface

The 3D image you see on your screen is the output of a virtual video camera fitted in the workcell. You can use the mouse to manipulate the image.

The Graphic Display and CellSetup in RoboCell have the same graphic interface.

3.1. ROTATE

To rotate the scene (move the camera around the center of the image):

1. Place the cursor anywhere in the graphic window and click the right mouse button. The cursor changes to a magnifying glass.
2. Keep the right mouse button depressed and drag to the right to rotate the scene counterclockwise.
3. Similarly, keep the right mouse button depressed and drag to the left to rotate the scene clockwise.

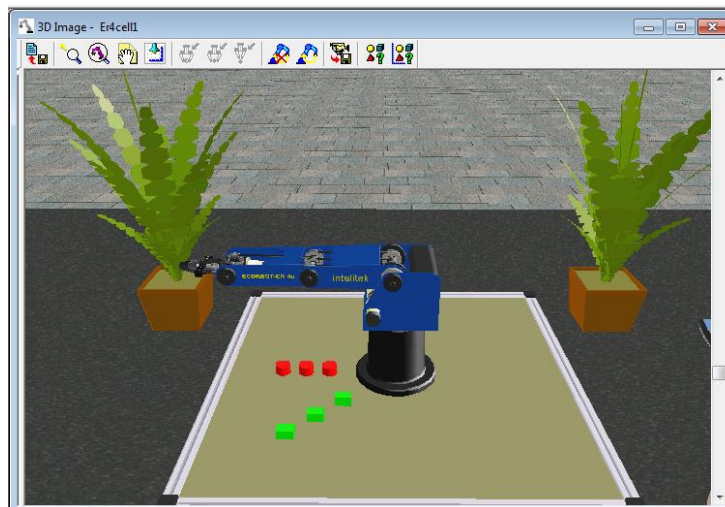

The image rotates around its center point. To change the center point, use the Redirect Camera tool (See 4.5 View Menu on page 15.).

3.2. ZOOM

To zoom in or out:

1. Place the cursor anywhere in the graphic window and click the right mouse button. The cursor changes to a magnifying glass.
2. Drag up to zoom in.
3. Drag down to zoom out.

The image zooms in and out while its center point remains fixed. To change the center point, use the Redirect Camera tool (See 4.5 View Menu on page 15.).

3.3. ANGLE

To change the angle of the overhead scene (to move the camera up or down), either click on the vertical scroll bar (red arrow) and drag it up or down or use the mouse scroll wheel.

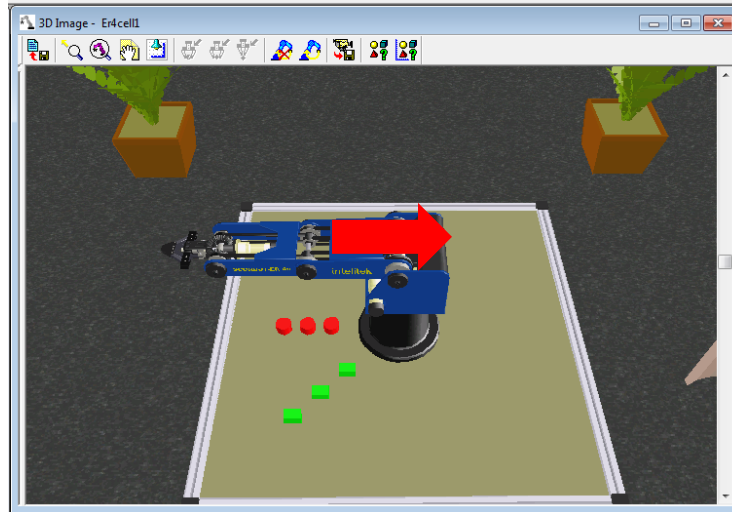

The camera moves up or down while the center point of the image remains fixed. To change the center point, use the Redirect Camera tool (See 4.5 View Menu on page 15.).

3.4. BRIGHTNESS

To change cell illumination (bright or dark), click the right mouse button and drag in any direction while simultaneously holding down the Ctrl key. The cursor changes to a light bulb.

4. CellSetup

CellSetup allows you to create a new virtual workcell or modify an existing one. A workcell created using CellSetup can be theoretical or a replica of actual robotic installations.

After creating a workcell, you can open it in RoboCell, where you can define positions, write programs and run them. If a controller and a robot are connected to your computer, you can switch RoboCell to On-Line, and run the virtual robot in the virtual cell, together with the real robot in the real cell.

4.1. OPENING CELLSETUP

To open CellSetup:

1. Select **Start | Programs | RoboCell | CellSetup**. After initialization, this screen is displayed:

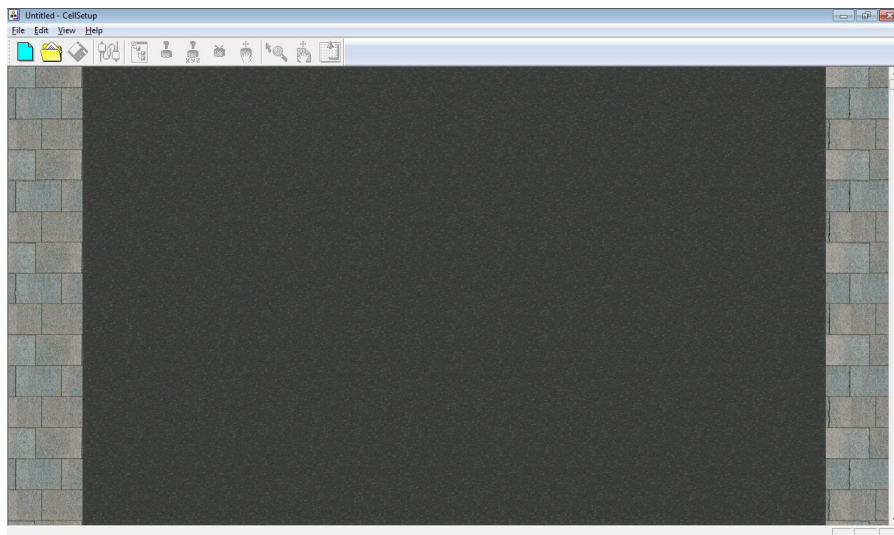

2. Select **File | New** to create a new workcell. At this stage, you can choose to work with either the default robot that you selected during installation or another robot.

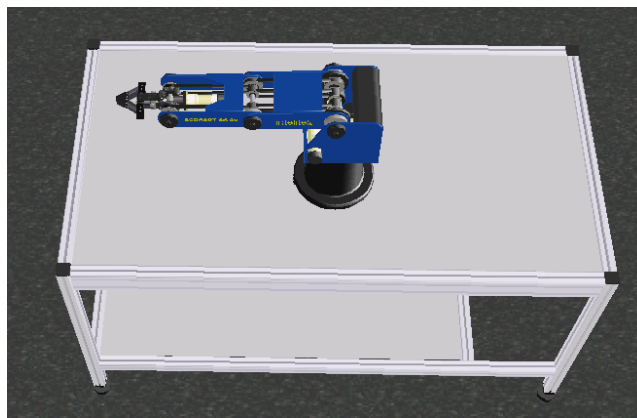

3. If you want to open an existing workcell, select **File | Open** from the Opening Screen. For further details, see 4.3 File Menu on page 13.

4. If you are working in RoboCell and you want to modify the current workcell you are using, select **File | Edit 3D Model**. CellSetup opens with your current workcell. At this point, you cannot open another cell. Therefore, the New and Open options are not available. When you exit CellSetup after having completed your modifications, you are returned to RoboCell where the newly edited cell is displayed.

4.2. CELLSETUP WINDOW

This image shows an existing workcell in the CellSetup window.

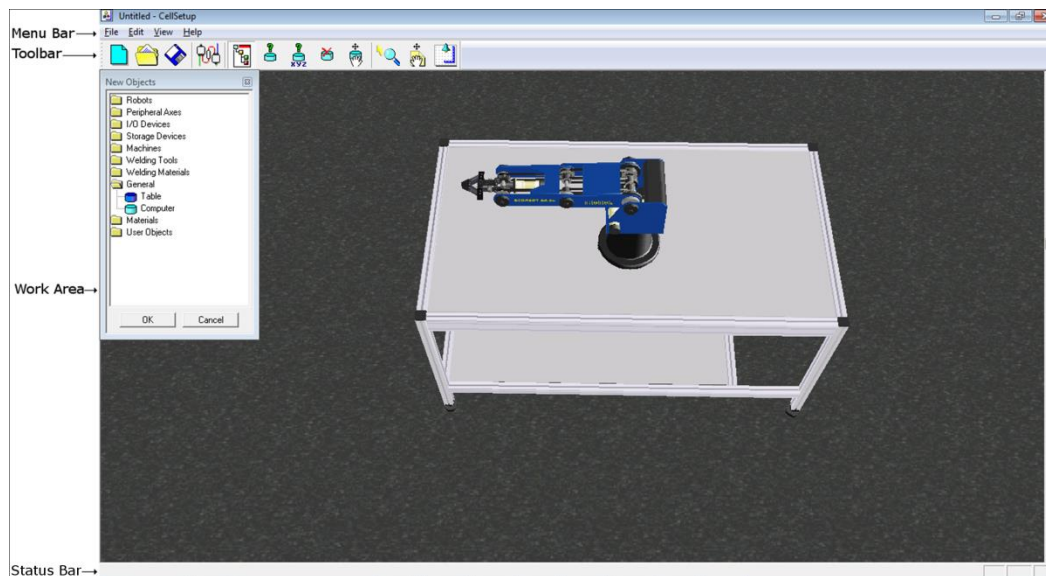

The window comprises:

- A menu bar containing all command menus and options
- A toolbar containing icons for the most commonly used options
- A working area containing the workcell objects
- A status bar displaying RoboCell status messages

4.3. FILE MENU

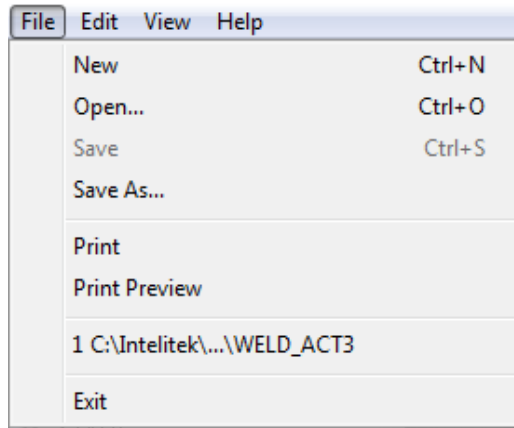

The file menu is shown here:



Cell data is stored in a *.3DC file. The File menu contains the usual Windows functions that allow you to load and save 3DC files, and to exit the software. In addition, you can open the most-recently opened workcell files from this menu.

Note: Only one workcell file can be opened at a time.

This table summarizes the options in the file menu.

File Menu		
Icon	Option	Summary
	New	After you select the robot that you want to work with (ER 4u), opens a new, untitled, CellSetup file, and opens the New Object menu. This icon and menu option are available only if CellSetup is opened from the Programs menu.
	Open	The Open dialog box is displayed. You can open an existing CellSetup file (e.g., robo1.3DC). The cell defined in the file is displayed, and the New Objects menu opens. This icon and menu option are available only if CellSetup is opened from the Programs menu.
	Save	Saves the current placement of all objects in the cell to a CellSetup file. The default file extension is 3DC.
	Save As...	Saves the currently active CellSetup file under a new file name. Note: <i>Peripheral axes are redefined (through the robot's properties menu) in the new file created by the Save As operation.</i>

File Menu		
Icon	Option	Summary
	Print	Prints the currently displayed 3D image.
	Print Preview	Opens a dialog window that shows how the printed cell appears on paper.
	Exit	Closes CellSetup.

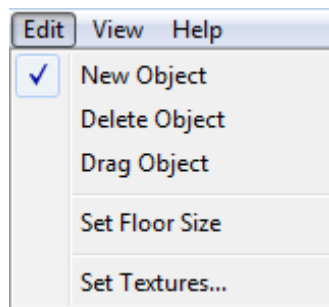

4.4. EDIT MENU

The edit menu is shown here:



The Edit menu contains functions that allow you to add, delete, and relocate objects. Through this menu you can also set the floor size and cell textures.

This table summarizes the options of the edit menu.

Edit Menu		
Icon	Option	Summary
	New Object	Opens/closes the New Object menu. From this menu you can select objects to add to the cell. For detailed information, see 4.8 New Objects Menu on page 20.
	Delete Object	Activates the delete mode in order to delete an object from the cell. Using the cursor, point and click the object you want to delete. Click Yes to confirm the deletion. If you click No , the delete mode remains in effect, allowing you to select and delete another object. Press [Esc] to cancel the delete mode.
	Drag Object	Activates the drag mode in order to relocate an object in the cell. Using the cursor, point and click the object you want to relocate and drag it to its new position. The drag mode remains in effect until you select another option or press [Esc] .
	Floor Size	Opens the Set Floor Size dialog box where you can set the X and Y dimensions of the cell. Click OK to confirm the new size or Cancel to close the dialog box.

Edit Menu		
Icon	Option	Summary
	Set Textures...	Opens a sub-menu listing cell textures: backdrop, ground, building and floor. Select Picture and click Edit to browse for a desired .bmp file or select Color and click Edit to define a color for the specified texture.

4.5. VIEW MENU

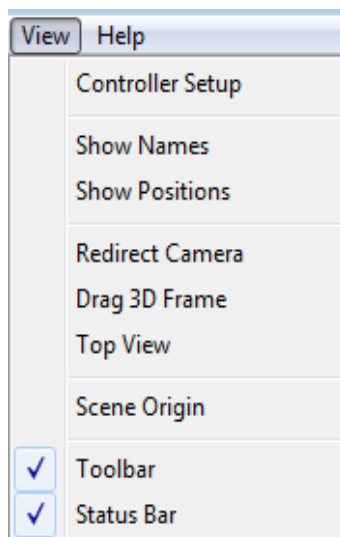

The View menu enables control of the position and name labels and the virtual camera position. Through this menu you can toggle the display of the Toolbar and Status Bar.

The view menu is shown here:

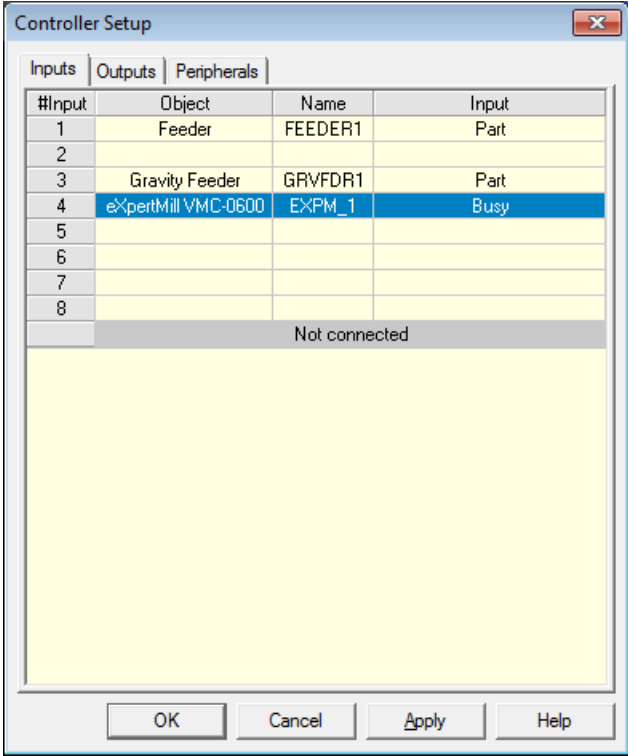

The options of the View menu are summarized in this table:

View Menu Options		
Icon	Option	Summary
	Controller Setup	<p>The robot controller has eight digital input and eight digital output connections. Certain objects that are placed in the cell have a predefined number of input and/or output positions at which they can be connected to the controller.</p> <p>In addition, peripheral devices can be connected to axes 7 and 8 of the controller (see 4.8.1.1 Robot Configuration on page 21 and 4.8.2 Peripheral Axes on page 23 below).</p> <p>Through the Controller Setup dialog box (below) you can view the defined objects and modify their input, output and axes connections under the appropriate tab.</p>

View Menu Options																																						
Icon	Option	Summary																																				
		 <p>The screenshot shows a 'Controller Setup' dialog box with three tabs: 'Inputs', 'Outputs', and 'Peripherals'. The 'Inputs' tab is active, displaying a table with the following data:</p> <table border="1"> <thead> <tr> <th>#Input</th> <th>Object</th> <th>Name</th> <th>Input</th> </tr> </thead> <tbody> <tr> <td>1</td> <td>Feeder</td> <td>FEEDER1</td> <td>Part</td> </tr> <tr> <td>2</td> <td></td> <td></td> <td></td> </tr> <tr> <td>3</td> <td>Gravity Feeder</td> <td>GRVFD1</td> <td>Part</td> </tr> <tr> <td>4</td> <td>eXpertMill VMC-0600</td> <td>EXPM_1</td> <td>Busy</td> </tr> <tr> <td>5</td> <td></td> <td></td> <td></td> </tr> <tr> <td>6</td> <td></td> <td></td> <td></td> </tr> <tr> <td>7</td> <td></td> <td></td> <td></td> </tr> <tr> <td>8</td> <td></td> <td></td> <td></td> </tr> </tbody> </table> <p>Below the table, there is a section labeled 'Not connected' with a large empty yellow area underneath. At the bottom of the dialog are buttons for 'OK', 'Cancel', 'Apply', and 'Help'.</p> <p>Devices that have not yet been connected are listed under Not connected.</p> <p>To connect a non-connected device, click the device and drag it to a free input/output/axis. A plus (+) sign is displayed next to the cursor.</p> <p>To modify an existing connection, drag the input/output/peripheral to a new setting. A swap sign is displayed next to the cursor. If you drag the device to a setting that already has a connected device, the new device replaces the previous device which is disconnected and relocated under Not connected.</p> <p>To disconnect input/output/peripheral, drag the object to the Not connected list. A minus (-) sign is displayed next to the cursor.</p>	#Input	Object	Name	Input	1	Feeder	FEEDER1	Part	2				3	Gravity Feeder	GRVFD1	Part	4	eXpertMill VMC-0600	EXPM_1	Busy	5				6				7				8			
#Input	Object	Name	Input																																			
1	Feeder	FEEDER1	Part																																			
2																																						
3	Gravity Feeder	GRVFD1	Part																																			
4	eXpertMill VMC-0600	EXPM_1	Busy																																			
5																																						
6																																						
7																																						
8																																						
	Show Names	<p>Shows/hides the Object Name labels (see the image below). When you select this option, a label on each object shows its name. Names are assigned by the software but can be renamed by the user in the object's properties menu.</p> <p>This option cannot be selected together with Show Positions.</p>																																				

View Menu Options		
Icon	Option	Summary
	Show Positions	<p>Shows/hides the Object Position labels (see the image below). When you select this option, a label on each object shows its position. The coordinates that are displayed on the object's label indicate the object's position (X, Y coordinates) relative to the cell's point of origin.</p> <p>This option cannot be selected together with Show Names.</p>
	Redirect Camera	<p>Allows you to select a different focal point in the graphic display of the cell.</p> <p>To change the center point of the graphic display window, click the icon or menu option. Use the cursor to point and click any spot in the scene. This now becomes the new center point of the display. All zooming of the view focuses on this point; all rotations revolve around this point.</p> <p>Press [Esc] to cancel the Redirect Camera mode.</p>
	Drag 3D Frame	<p>Activates the drag mode in order to relocate the entire cell in a new position. Click anywhere in the image and drag the entire cell to a new position.</p> <p>The drag mode remains in effect until you select another option or press [Esc].</p>
	Camera Top	<p>Resets camera position to display an overhead view of the cell. You can rotate or zoom in/out of this view. Use the vertical scroll bar or the mouse scroll wheel to alter the angle of the view.</p>
	Scene Origin	<p>Shows the origin of the cell at floor level (under the center of the robot's base) as a red cross marked with X and Y axes. The positions of all objects are defined</p>

View Menu Options		
Icon	Option	Summary
		as relative to this point of origin. When manipulating the graphic display, the cross may disappear momentarily. Rotating the view does not change the X and Y dimensions of the cell.
	Toolbar	Shows/hides the Toolbar.
	Status Bar	Shows/hides the Status bar.

4.6. HELP MENU

The options of the Help menu (shown here) are summarized in the table below.

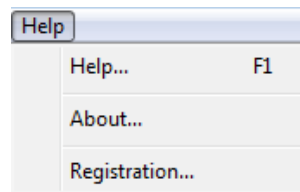

Help Menu	
Option	Summary
Help	Opens RoboCell on-line help
About	Shows the RoboCell software version
Registration	Opens the Software License Window for registration, and for transferring RoboCell license to another computer. (See the Intelitek Software licensing Guide for further information.)

4.7. OBJECTS

You can place a number of objects into the workspace using RoboCell.

4.7.1. Object Placement

To place a new object in the cell, do the following:

1. Double click the object's name in the New Objects menu.
2. Move the cursor into the graphic scene.
3. Point and click the location where you want to place the object. You may need to wait a moment for it to be displayed. *Do not double click.*

If you have trouble placing an object in the exact spot you want, zoom in and out, and adjust the view from top to bottom until you can more accurately place the object.

Most objects are placed in the cell automatically at table level. These objects look as if they float in space unless a table has also been placed in the cell.

The height of some objects (template, jig, cylinder and cube) is determined at the time they are placed in the cell.

If, for example, you click the conveyor when placing a cube in the scene, the cube is placed on the conveyor at the proper height.

It is recommended that a table be placed in the cell before any of these four objects is added to the cell. Otherwise, these objects may be set on the cell floor and are hidden when a table is added.

Once an object's height is set, it cannot be changed in CellSetup. For example, you cannot move the cube from the table onto the conveyor. Moving an object whose height has been set causes it to float in space or penetrate another object. If the setup is saved with a floating object, the object falls to the surface below it when the file is loaded in RoboCell.

To change an object's height in CellSetup, you must delete the object and create a new one.

To move an object, simply click it and drag it to another position. Or use the object's properties menu to set precise position coordinates.

The robot cannot be dragged to another position. Its position can be changed only by means of its properties menu.

4.7.2. Object Configuration

Selecting some of the objects from the New Object list opens a configuration dialog box for defining the object's permanent attributes (such as size and color). Attributes must be set before an object can be placed in a cell.

An object's configuration cannot be changed once the object has been placed in the cell. You must delete the original object, and select and configure the object again from the New Object list.

Objects that have configuration options are described later in this section.

4.7.3. Object Properties Menu

Double-clicking an object that has already been placed in the cell opens the Object Properties menu.

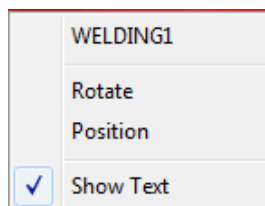

Object properties can be changed at any time during cell setup.

All Object Properties menus contain the object's name and the following options. Some objects have additional properties which are described in the individual sections. The Object properties menu is shown here. A table that summarizes the options is shown below.

Object Properties Menu	
Option	Summary
Rename	<p>Every object is automatically assigned a name and a number when it is placed in the cell. This name is displayed in the object's properties menu. The number indicates the order in which objects of the same type were added to the cell (e.g., FEEDER1, GFEEDER2).</p> <p>Clicking Rename opens a dialog box that allows you to change the name of the object. The number can be changed or deleted.</p>
Rotate	<p>Objects can be rotated to any degree, in the minus (clockwise) or plus (counterclockwise) direction.</p> <p>Clicking Rotate opens a dialog box that allows you to change the object's orientation.</p> <p>The degree of rotation is always defined relative to the object's default (predefined) orientation.</p>
Position	<p>The cell has a point of origin at table level defined by XY coordinates (0,0). All object positions are defined in XY coordinates relative to this point of origin.</p> <p>For most objects these XY coordinates indicate the center of the object's base.</p> <p>By default, the robot is placed in the cell with the center of its base (i.e., the robot's point of origin) at the cell's point of origin.</p> <p>Clicking Set Position opens a dialog box that allows you to change an object's X and/or Y coordinates.</p>
Show Text	<p>Shows/hides the label for the selected object.</p> <p>This option can only be activated when View Object Names or View Object Positions is selected.</p>

4.8. NEW OBJECTS MENU

New objects are added to the cell using the New Objects menu. The objects are arranged in groups (robots, peripheral axes, etc.).

To add a new object to the cell, click the desired object group (folder) and then select the specific object. The groups are detailed below.

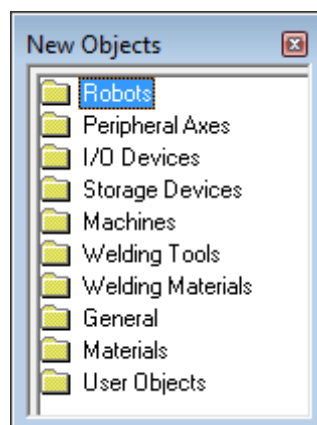

4.8.1. Robots

The robot, which is automatically placed at the cell's point of origin, should be the first object you place in the cell.

The robot cannot be dragged to a new location. Its position can be changed only by means of the robot's Properties menu (see 4.7.3 Object Properties Menu, page 19).

Only one robot can be placed in the cell.

To add a robot to the cell:

- Click **Robots**. Select **ER 4u**.

4.8.1.1. Robot Configuration

A dialog box titled ROBOT1 opens allowing you to define whether or not the robot is mounted on a linear slidebase (LSB), a peripheral device that enables linear movements of the robot unit.

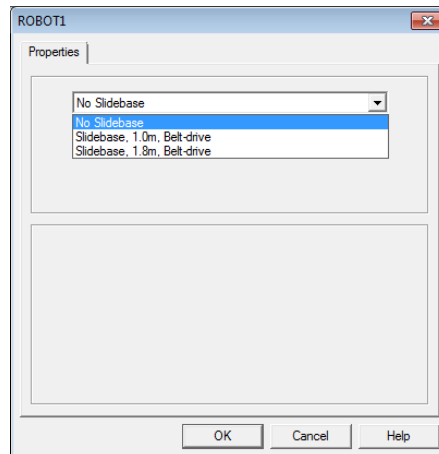

By default, the robot is set to have no slidebase. When you click **OK** to confirm this option, the robot is immediately placed in the cell.

Alternatively, these slidebase options are available:

- Slidebase 1.0m, Belt drive
- Slidebase 1.8m, Belt drive

If you select a slidebase, the Robot Configuration dialog box looks as follows:

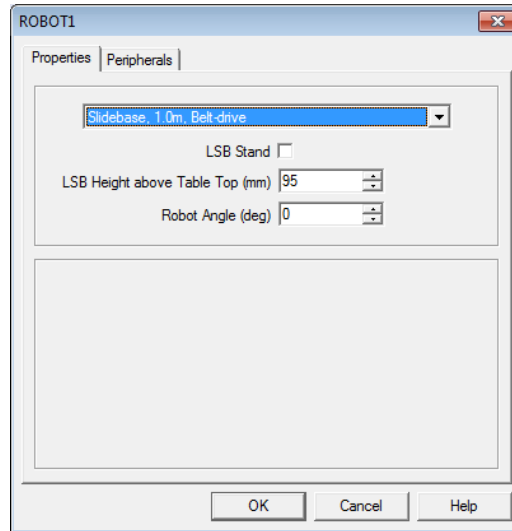

Robot Configuration Dialog Box Properties Tab	
LSB Height	By default, the LSB Height is 100 mm, which is the actual height of standard SCORBOT slidebases.
Robot Angle	By default, the robot is mounted perpendicular to the slidebase at 90°.

If you select a slidebase, the robot and the slidebase are treated as one object in the cell.

4.8.1.2. Peripherals tab:

To select a controller peripheral axis that controls the slidebase (and any other peripheral device that has already been defined), click the Peripherals tab.

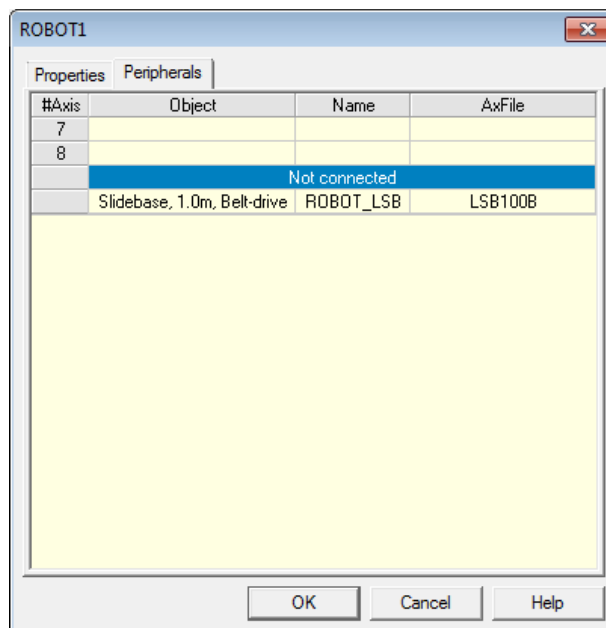

Peripheral devices can be connected either to axis 7 or to axis 8. To connect a device listed under **Not connected**, click it and drag it to one of the free controller axes. If you drag the device to an axis that

already has a connected device, the new device replaces the previous device which is disconnected and relocated under **Not connected**.

You can leave the slidebase not connected at this stage and connect it later using **View | Controller Setup**, or the Controller Setup icon.

4.8.1.3. Additional Robot Properties

In addition to the standard object properties (see 4.7.3 Object Properties Menu on page 19), this option is listed as a Robot property:

Additional Robot Properties	
Show Envelope	Displays the span of the robot's working range. This option facilitates the placing of objects within the reach of the robot.

4.8.2. Peripheral Axes

Peripheral devices include a motor with speed and position control. They are connected as axis 7 or axis 8 of the controller.

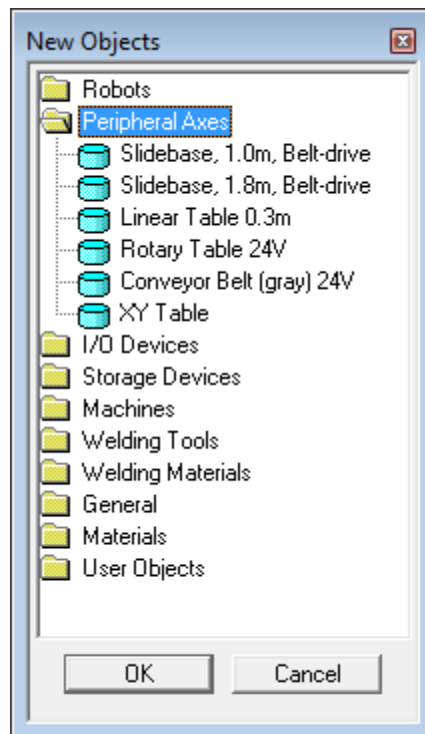

To place a peripheral device in the cell, click **Peripheral Axes** and select the required device.

If you select either of the slidebases or a linear table, you are asked to define the LSB Height as described in 4.8.1.1 Robot Configuration on page 21.

For all devices you have the opportunity of allocating the controller axis at this stage (see 4.8.1.1 Robot Configuration on page 21).

4.8.3. I/O Devices

RoboCell I/O (input/output) devices can be connected to any free input/output terminal. The robot controller has eight digital input and eight digital output connections.

To place an I/O device in the cell, click the I/O Devices group and select the required device.

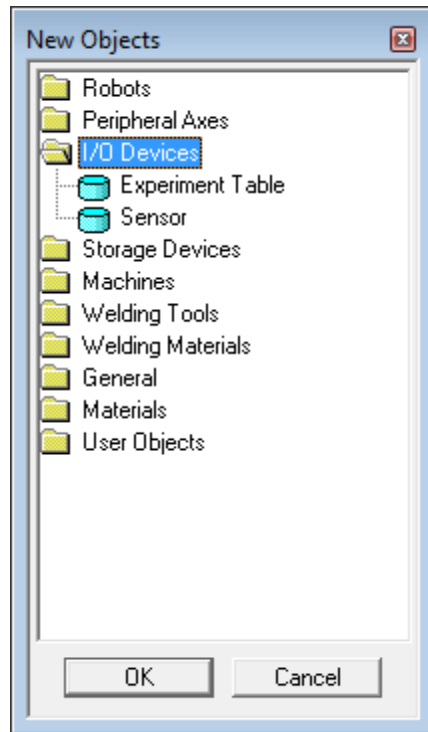

4.8.3.1. Experiment Table

An experiment table includes the following input and output devices:

- Four (4) touch sensors – (input device). These are activated when there is a part on the switch, or something activates the switch.
- Lamp (output device)
- Buzzer (output device)

An experiment table with Input/Output Devices is shown here.

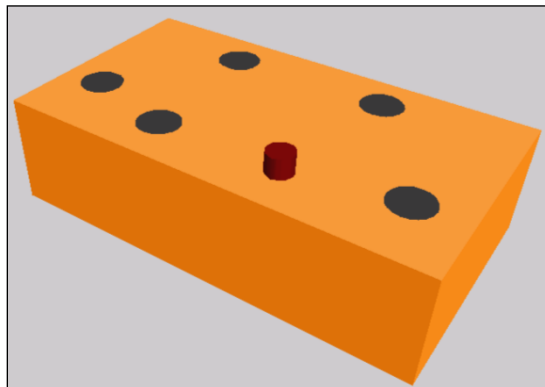

When you select **Experiment Table**, this dialog box is displayed, enabling you to define the input and output connections:

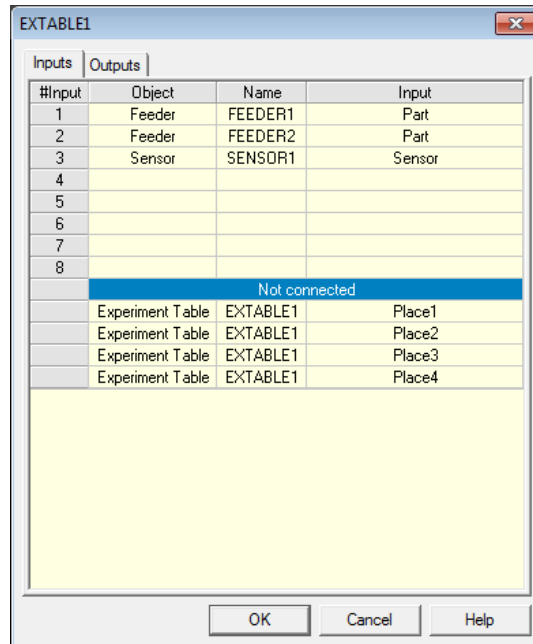

Although one of the experiment table inputs may be disabled if the input is later defined for another device, all other switches remain connected to their defined inputs.

In RoboCell, a sound is emitted when the outputs that control the buzzer and lamp are turned on and off. The experiment table outputs use the Windows sounds associated with the following events:

- Buzzer On: Exclamation
- Buzzer Off: Critical Stop
- Lamp On: Asterisk
- Lamp Off: Information

In addition, the lamp in the Graphic Display turns bright red when its associated output is turned on.

4.8.3.2. Sensor

RoboCell includes digital sensors that can be configured to detect specific objects based on their color and/or material (metal, plastic, wood, etc.). The objects are listed in the Materials group and their properties are defined when they are placed in the cell (For more information, see 4.8.10 User Objects on page 39.).

When you select **Sensor**, this dialog box is displayed, enabling you to define the color/material to which the sensor is sensitive, as well as the sensor's height.

The sensor configuration window is shown here:

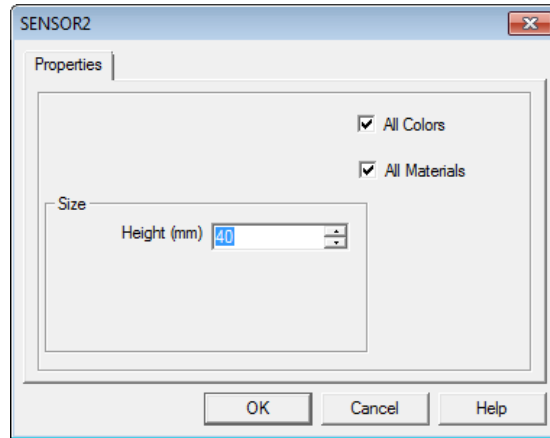

Sensor Configuration	
Option	Description
Color Detect	<p>By default, the sensor is set to detect all colors. To set it to a specific color, uncheck All Colors. Click Color Detect to open a color palette from which you can select the required color.</p> <p>If the sensor is configured to be sensitive to All Colors, the sensor in the cell is colored different shades of gray with its upper part in white. This distinguishes it from a sensor configured to be sensitive to gray, which is entirely gray.</p>
Material Detect	<p>By default, the sensor is set to detect all materials. To set it to a specific material, uncheck All Materials. Select a material (Metal, Glass, Plastics, or Wood) from the drop-down list.</p>
Height (mm)	<p>Defines the height (above table level) at which the sensor is placed in the cell.</p> <p>The default height is 40 mm. If you increase the height, the stand on which the sensor is mounted appears taller.</p>

4.8.4. Storage Devices

The storage devices in RoboCell enable you to store, place and retrieve objects listed in the Materials group.

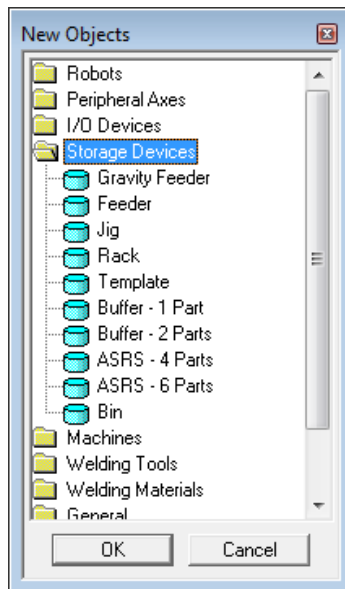

4.8.4.1. Gravity Feeder

The Gravity Feeder is an inclined plane on which objects are placed, one above the other.

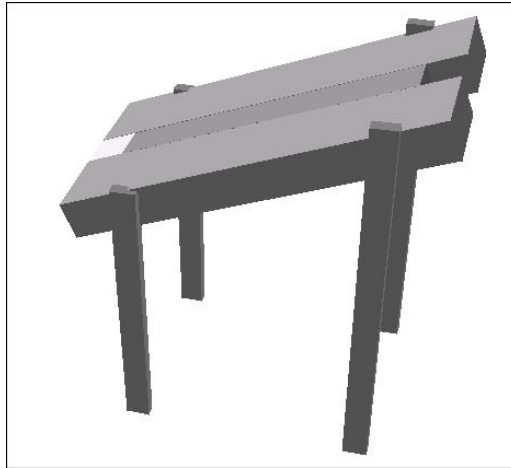

Unlike most objects, the feeder's position is defined as the point at which the robot takes an object from the lower part of the feeder. All the remaining objects slide down the feeder to be taken in turn.

When placing objects on the gravity feeder, you must position them in the light gray section of the feeder's mouth. This is shown here:

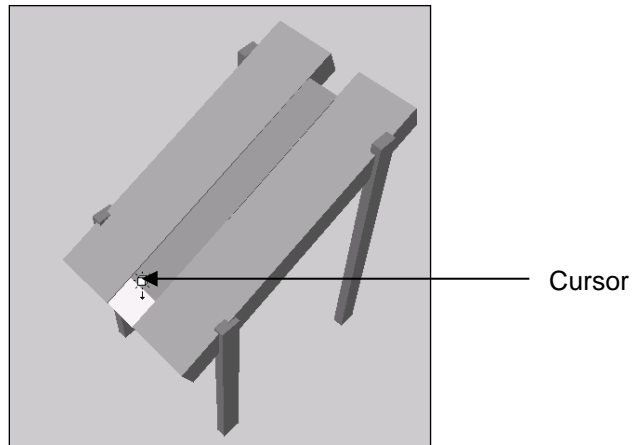

The feeder is fitted with a touch sensor (named NotEmpty) located at the lower part of the feeder. The sensor indicates when there are parts in the feeder, i.e., it is on when the feeder is not empty.

4.8.4.2. Feeder (Pneumatic Feeder)

The (pneumatic) feeder is constructed from a magazine of objects and a pneumatic cylinder fitted at the lower section.

The feeder is also fitted with a touch sensor that is pressed (the input is on) when there are parts in the feeder (NotEmpty sensor)

The pneumatic cylinder is controlled via a controller output. When the output is turned on, the piston extends, pushing out the next object.

The robot picks the objects from the feeder output tray, and the feeder position is defined as the point at which the robot takes an object from the feeder.

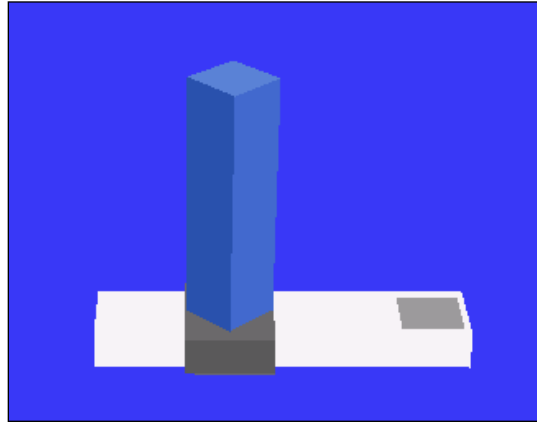

4.8.4.3. Feeder Configuration

Configuration for the Gravity Feeder and the Pneumatic Feeder is described below. The differences between the two methods are indicated.

When you select a feeder, this configuration dialog box is displayed:

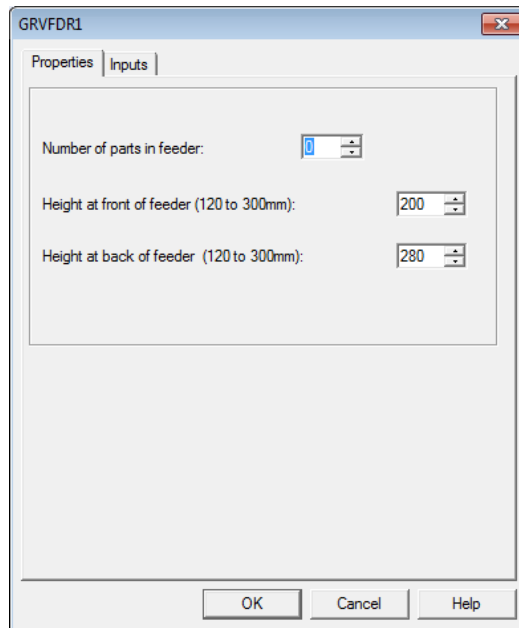

Feeder Configuration Properties tab:	
Number of Parts in Feeder	Defines the number of parts that are loaded in the feeder at the start of operation (when the cell is opened or reset). Only one material object (e.g., cylinder, cube) should be placed in a parts feeder. The software multiplies the object by the number of parts specified. Default: 0
Height at Front of Feeder (Gravity Feeder only)	Defines the height of the lower part of the feeder above the table level. Default: 200
Height at Back of Feeder (Gravity Feeder only)	Defines the height of the higher part of the feeder above the table level. Default: 280

Inputs tab:

To define the robot controller input to which the feeder's NotEmpty sensor is connected, click the Inputs tab.

Outputs tab: (Pneumatic Feeder only)

To define the robot controller output to which the feeder is connected, click the Outputs tab. A new part appears in the feeder when the output is turned on.

Feeder Properties

In addition to the standard object properties (see 4.7.3 Object Properties Menu on page 19), this option is also listed in the Feeder Properties menu:

Additional Feeder Properties	
Capacity	Enables you to alter the number of parts loaded in the feeder after the feeder has been configured.

Jig, Rack, Template, Buffers, ASRS and Bin

No settings are required for these storage devices. Double click the desired device and place them in the cell at the desired location.

4.8.5. Machines

The Machines group includes four Mills (spectraLIGHT Mill 0200, proLIGHT Mill 1000, eXpertMill VMC-0600, Super proLIGHT Mill 1000) and two Turns (spectraLIGHT Turn 0400, proLIGHT Turn 3000). A CNC controller controls these machines. The robot controller and the machine controller communicate through inputs and outputs. The machine output is the controller input, and vice versa.

All of these machines are configured in the same way.

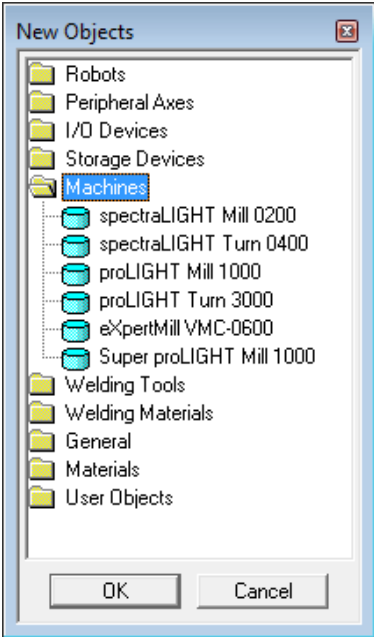

When you select any of these machines, this configuration dialog box is displayed:

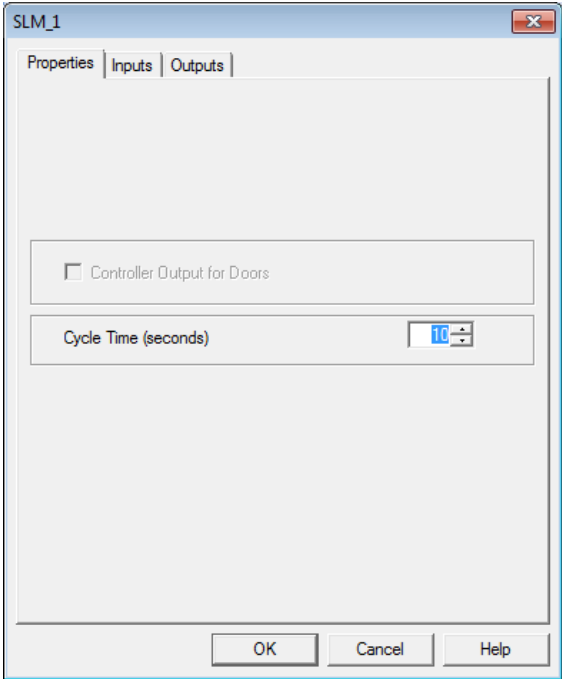

Machine configuration properties tab:	
Controller Output for Doors	Specifies whether or not the machine doors are controlled by the robot controller output. If the doors operate independently of the robot controller, they open and close at the beginning and end of the machine cycle.
Cycle time (seconds)	Sets the amount of time (in seconds) of the machine process. The default cycle time is 10 seconds.

Machine configuration inputs tab:	
Controller input (machine output)	The machine informs the controller that a process is being carried out, i.e., when the input is on, the machine is busy.

Machine configuration outputs tab:	
Controller output (machine input)	Closes and opens the machine door. The machine cannot start if the door is open.
Controller output (machine input)	Closes and opens the machine chuck. The chuck holds the object during the process.
Controller output (machine input)	Sets the robot controller output to which the machine is connected. The machine cycle starts when the output is turned on.

To modify the configuration after the machine has been placed in the cell, double-click the machine to display its Object Properties menu (see 4.7.3 Object Properties Menu on page 19). Select **Machine Setting** to display the Configuration dialog box.

4.8.6. Welding Tools

The Welding Tools menu is shown here:

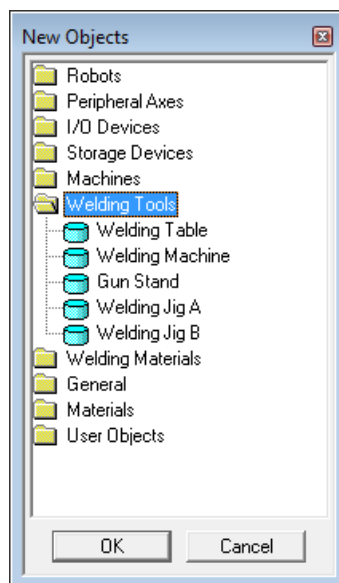

The Welding Tools group includes:

- Welding Table
- Welding Machine
- Gun Stand
- Welding Jig A
- Welding Jig B

Full details on use of the welding tools are provided in chapter 7 Welding Features on page 57.

Welding Tools	
Welding Table	The welding table holds the welding object and it should be placed in the cell just before or after the robot (the first object) has been placed. Most welding objects are automatically placed at the correct default welding table height, even if they are not placed directly on the welding table.
Welding Machine	The welding machine supplies the electrical power required to weld the materials. It is connected to the welding gun by a cable. You cannot save a cell containing only a welding gun or only a welding machine. Neither or both must be present in order to save the cell.
Gun Stand	The gun stand holds the welding gun between welding sessions. The robot picks the gun from the stand before starting the weld, and returns it to the stand when the welding is finished.
Welding Jig A	Welding Jig A is a device used to securely hold two materials being welded together in a T-joint.
Welding Jig B	Welding Jig B can be used for various types of welds.

4.8.7. Welding Materials

The Welding Materials group includes the plate and the metal cube.

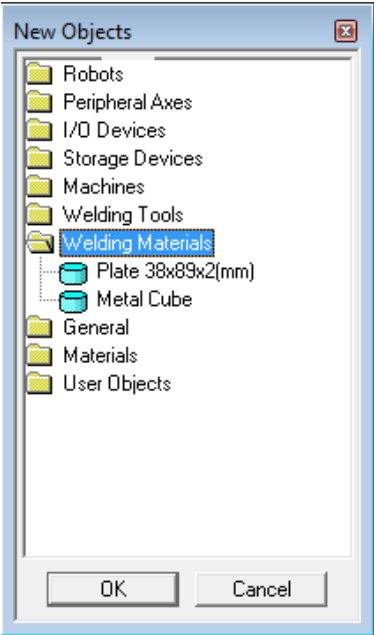

Use of the welding materials is detailed in chapter 7 Welding Features on page 57.

4.8.7.1. Plate

Plate refers to the welding metal plates which are used with Welding Jig A. When you select **Plate**, this dialog box is displayed:

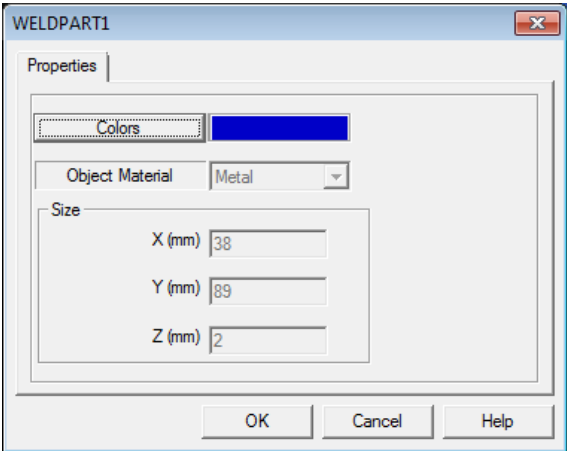

This table summarizes the options of the Plate Configuration dialog box.

Plate Configuration Dialog Box	
Option	Description
Colors	You can define the color of the plate to which the sensor is sensitive. The default color is blue. To change the color, click Colors . This opens a color palette from which you can select the required color. Make sure the color you select is compatible with the sensor's detection definition.
Size	The default dimensions of the plates are 38 x 2 x 89 mm. These are for display purposes only and cannot be changed.

4.8.7.2. Metal Cube

When you select **Metal Cube**, this dialog box is displayed:

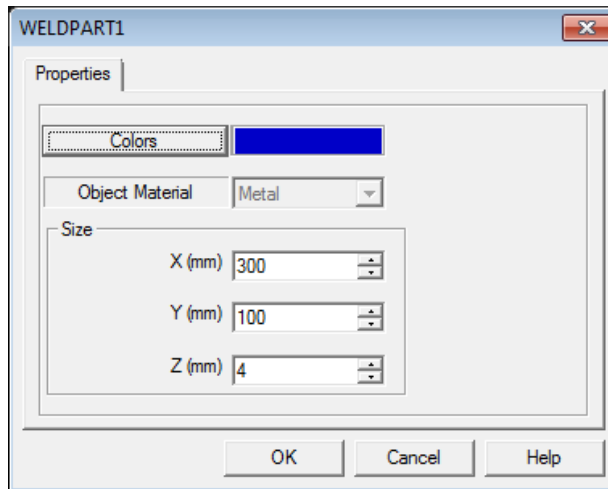

The Metal Cube dialog box is described in this table:

Metal Cube Configuration Dialog Box	
Option	Description
Colors	Define the color of the cube in the same way as described for the plate.
Size	The default dimensions of the cube are: 300 x 4 x 100 mm. You can modify these dimensions.

4.8.8. General

The General group includes a table and a computer (which is for display purposes only).

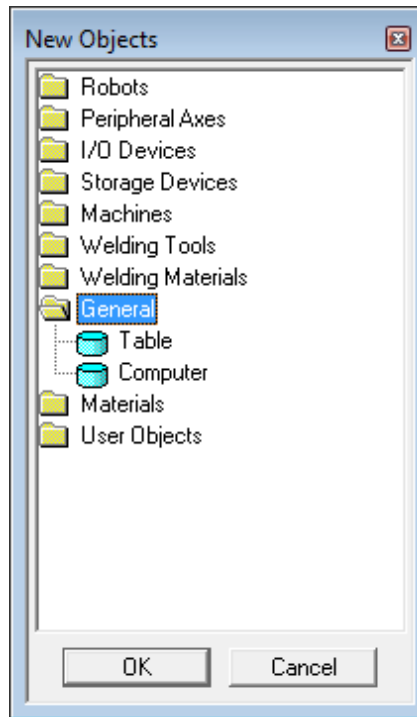

4.8.8.1. Table

It is a good idea to place the table in the cell just before or after the robot has been placed. It is also recommended that you place one or more tables in the cell so that objects do not float in space or lie on the floor. Most objects are displayed at the correct height, even if they are not sitting on tables.

When you select **Table**, this dialog box is displayed:

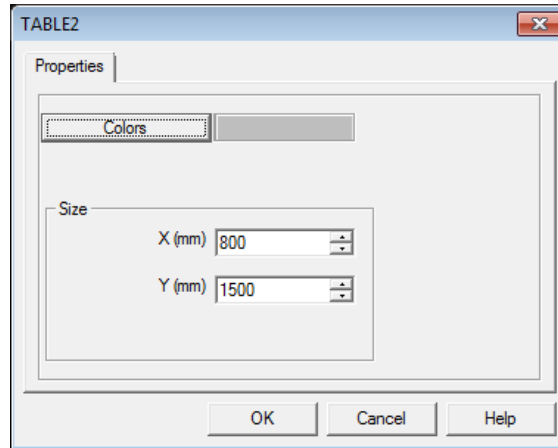

The dialog box is described in this table:

Table Configuration	
Option	Description
Colors	To change the color, click Colors . This opens a color palette from which you can select the required color.
Size	Defines the width and length of the table. X and Y dimensions are always in accordance with the X and Y dimensions of the cell. (Use the View Scene Origin option to display the X and Y dimensions of the cell.)

4.8.8.2. Table Properties

The Table Properties menu does not have a Rotate option (see 4.7.3 Object Properties Menu 19). Instead it has a Resize option for scaling the table's dimensions.

Table Properties	
Scale X; Scale Y	Enter a ratio value (e.g., 2 or 0.5) in the X and Y fields. Both fields must contain a value. If you want to change only one dimension, be sure to enter 1 in the other field (do not enter 0). Resizing is progressive. The scale reverts to 1 each time the table is resized.

4.8.9. Materials

The Materials group includes objects that can be manipulated by the robot:

- Cube
- Cylinder
- Ball
- User defined parts (see 4.8.10 User Objects 39 below)

You can place as many objects as needed.

The Materials Menu is shown here:

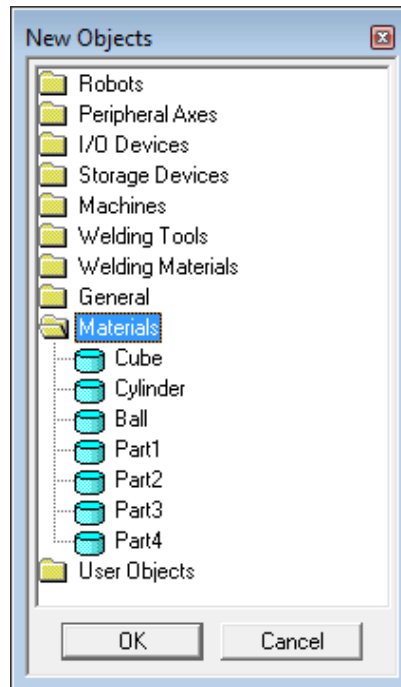

When you select **Cube**, **Cylinder**, or **Ball**, the Object Configuration dialog box is displayed:

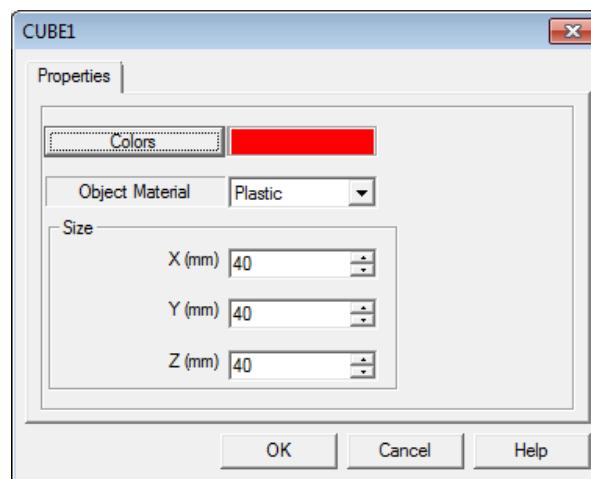

The options of the Object Configuration dialog box are summarized here:

Object Configuration Dialog Box	
Option	Description
Colors	You can define the color of the plate to which the sensor is sensitive. The default color is red. To change the color, click Colors . This opens a color palette from which you can select the required color. Make sure the color you select is compatible with the sensor's detection definition.
Object Material	The cell sensor can differentiate between different materials. The default material is plastic. Other available materials are glass, metal and wood. When metal is selected, you can perform welding using the features described in Chapter 7, Welding Features.
Size (mm) Cube: X, Y, Z Cylinder: Diameter, Height Ball: Diameter	The default dimensions of the objects can be modified if desired.
Horizontal/Vertical (for Cylinder only)	Defines whether the cylinder is placed in a horizontal or vertical position. Cylinders that are placed in the lathe should be defined as horizontal.

4.8.10. User Objects

To insert an object or a part, select the desired part/object from the Materials/User Objects group.

Point and click the location where you want to place the part/object. You may need to wait a moment for the cursor to be displayed. Do not double click.

The User Object menu is shown here:

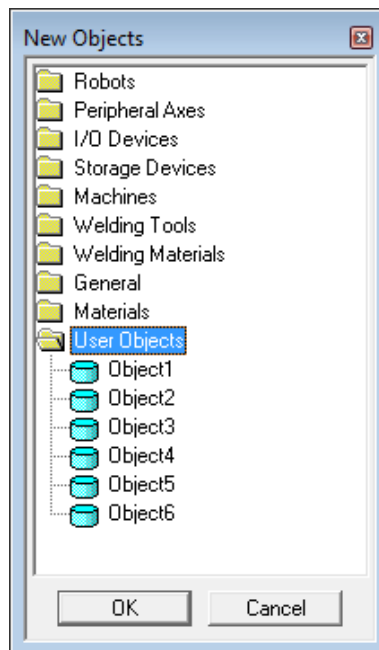

4.8.10.1. Parts

Parts are basic shapes that can be used to simulate any type of material the user chooses. Simply click Part 1, 2 or 3 to add a new part to the cell.

In RoboCell, parts are changed to show what they look like at the end of the mill or lathe machining process. You may design your own finished parts.

User parts are stored as files in RWX format. The robot and machines can manipulate these objects. User part files are saved as PART*_0.RWX (where * represents 1, 2, or 3), and finished parts are named PART*_1.RWX. The files are located in the SBWSIMn RESOURCE folder.

4.8.10.2. Objects

The objects included in the User Objects group are for illustration purposes only. User Object files are named USER*.RWX. The files are located in the SBWSIMn\RESOURCE folder.

Advanced users who know how to create 3D objects in RWX format can design and use such objects in the robotic cell. No more than three user-defined parts and eight user objects may be used at one time. For further directions on designing user parts/objects, see 4.8.11 Designing User Parts and Objects on page 40.

4.8.11. Designing User Parts and Objects

RoboCell invites you to design your own parts and objects. Part design is covered in the sections below.

4.8.11.1. Modify an Existing User Part File

You may change the existing user part to create your own user part. To modify an existing user part, do the following:

1. Open the SBWSIMx folder.
2. Open the RESOURCE folder.
3. Using a text editor that saves files in plain ASCII format, such as Notepad, open one of the existing user part files (PART1_0.RWX, PART2_0.RWX or PART3_0.RWX). The file looks like the following example:

```
ModelBegin
TransformBegin
    Color 0.0 1.0 1.0
    Surface 0.4 0.3 0.2
    Opacity 1.000000
    LightSampling Facet
    GeometrySampling Solid
    TextureModes Lit
    Texture NULL
    ClumpBegin
Translate 0.0 0.0251 0.0
```



```
Tag 1
Block 0.05 0.05 0.05

ClumpBegin
Tag 2001
Color 1 0 0
Opacity 1
Block 0.03 0.02 0.07
ClumpEnd
    TransformEnd
ModelEnd
```

4. Edit the file to create your own part.
5. Save the file. Since you can only have three user part files at a time, you must replace the original file. *Do not change the file name.*
6. To create your own finished part, edit the Part*_1 file.

If you do not want to create a finished part, delete the Part*_1 file.

4.8.11.2. Create a New Part/Object File

If you can create your own user part and user object files, perform the following:

1. Open a text editor that saves files in plain ASCII text, such as Notepad or DOS Edit.
2. Write the program to create your own part.
3. Save as file type .RWX. (You must name the file PART1_0.RWX, PART2_0.RWX, or PART3_0.RWX.)
4. To create a finished part, name the file PART*_1.RWX. There must also be a PART*_0.RWX file to go with it (i.e., in order for there to be a PART1_1 file there must be a PART1_0.RWX file).
5. Copy the files to the SBWSIMn\RESOURCE folder.

Note: It is recommended that you do not discard the original files supplied with RoboCell. Save the original files under different file names.

6. To create a User Object, follow the above steps and name the file USER*.RWX. USER*.RWX files cannot be manipulated by the robot or machines. You must replace the original user object files.

4.8.11.3. Import a CAD File

You can create a 3D object in a CAD program, and import it to RoboCell. To import a CAD file do the following:

1. Create a file in any CAD program. Save as *.DXF or *.3DC.
2. Use the *DXFtoRWX*, or *3DCto RWX* converter to convert the file to RWX format.



3. Name the files PART1_0.RWX, PART2_0.RWX, or Part3_0.RWX.
4. To create a finished part, name the file PART*_1.RWX. There must also be a PART*_0.RWX file to go with it (i.e., in order for there to be a PART1_1.RWX file there must be a PART1_0.RWX file).
5. Copy the file to the SBWSIMn\RESOURCE folder.

To import a *user object*, follow the above steps and name the file USER*.RWX.

For more information on RWX files, consult a manual on RWX programming.

5. Working in RoboCell

RoboCell integrates the SCORBASE robotic software with a graphic display module, which allows you to define (teach) robot positions and execute robot programs in a virtual robotic workcell.

RoboCell's user interface and menus are similar to those of SCORBASE. The main differences are detailed in this chapter. They include:

- The graphic module, which enables position definition and SCORBASE program execution in a virtual or real workcell.
- Additional options which facilitate the integration of SCORBASE in RoboCell are displayed in RoboCell menus.

All SCORBASE operations, menu items and programming language are described in the SCORBASE User Manual.

5.1. ROBOCELL MENUS

When you open Robocell and select **New Project**, this window is displayed:

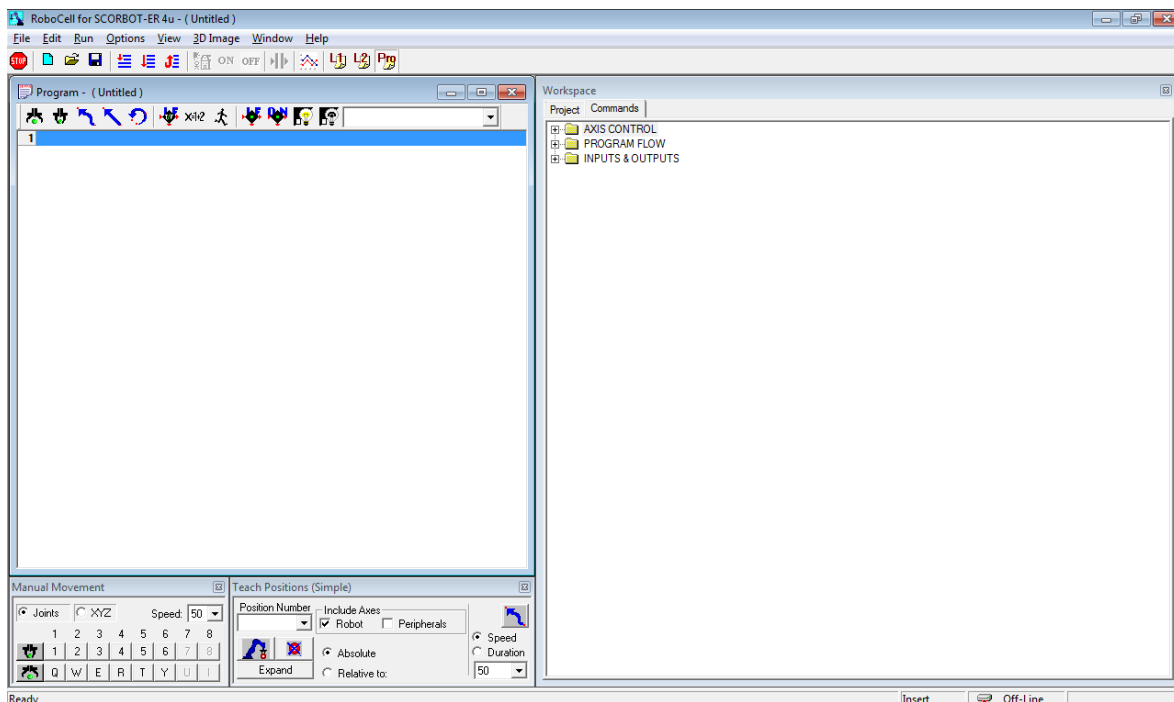

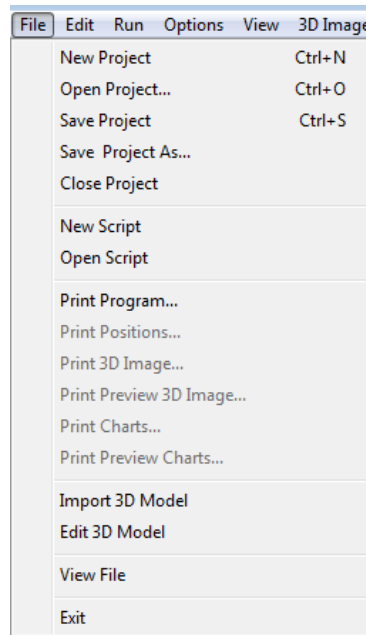

5.1.1. File Menu

The following options are available in the File menu:



The following table summarizes the options in the File Menu.

File Menu		
Icon	Option	Description
	New Project	<p>This option opens a new untitled project.</p> <p>The new untitled project does not include a robotic workcell (3D window). To add a workcell, perform one of the following:</p> <ul style="list-style-type: none"> • Select File Import 3D model to open an existing workcell file. • Select File Edit 3D model to open CellSetup and create a new workcell.
	Open Project	Opens the Load Project window which lists SCORBASE files (without a virtual cell), and RoboCell files (that include a virtual cell)
	Save Project	Saves the project (program, positions and graphics)
	Save Project as...	Saves the project (program, positions and graphics) under a different name
	Close Project	Closes the currently open project
	New Script	Opens Notepad
	Open Script	Opens File Selector box for opening an existing Visual Basic script file
	Print Program	Prints the SCORBASE program

File Menu		
Icon	Option	Description
	Print Positions	Prints the positions defined by the user
	Print 3D image	This option prints the graphic cell. The output is an image of the current cell.
	Print Preview 3D Image	Opens a dialog window that shows how the printed cell appears on paper
	Print Charts	This option opens a dialog box to select the chart of a specific axis for display or printout. Only one axis can be selected at a time.
	Print Preview Charts	Opens a window that displays the chart of the selected axis showing how it is displayed on paper
	Import 3D Model	This option opens the Import 3D Model window which lists graphic module files (*.3DC files). Select one of the files to open the graphic display module window. When you save the project, the current workcell is included as part of the project.
	Edit 3D Model	This option opens CellSetup. If the project already includes a workcell, CellSetup opens that workcell for editing. Otherwise, CellSetup opens with a new untitled empty cell.
	View File	This option opens the View File window which lists the following files: <ul style="list-style-type: none"> • Graphic module files (*.3DC) • SCORBASE programs (*.sbp) (Note: It is possible to copy and paste an sbp file into your own project.) • Position data (*.pnt) When you select a file, a window opens displaying that file.
	Exit	Closes RoboCell

5.1.2. Edit Menu

The Edit menu is identical to the SCORBASE menu, which is used to edit SCORBASE programs. See the SCORBASE User Manual (or Help file) for a description of this menu's options.

5.1.3. Run Menu

The Run menu is identical to the SCORBASE menu whose options allow you to run the SCORBASE programs and send the robot home.

If you select **Options | Simulation**, running a SCORBASE program runs the robot in the virtual cell.

If you select **Options | On-Line** (and a robot connected to the computer) the virtual and real robot work together.

5.1.4. Options Menu

The Options menu is similar to the SCORBASE menu. The only difference is the Simulation option. When checked, the robot in the virtual cell runs according to the SCORBASE program instructions. See the SCORBASE User Manual (or Help file) for a description of this menu's options.

Note: Advanced Commands are detailed in the SCORBASE User Manual. The ViewFlex Commands are detailed in the ViewFlex User Manual.

5.1.5. View Menu

The View menu is identical to the SCORBASE menu whose options allow you to toggle the display of SCORBASE dialog bars and menus.

5.1.6. 3D Image Menu

The options of this menu are described in 5.2 Graphic Display Module on page 46.

5.1.7. Window Menu

The options of the Window menu offer screen settings that enable optimal use of the screen while you are carrying out various operations such as defining positions, programming, and running the SCORBASE programs.

5.2. GRAPHIC DISPLAY MODULE

The graphic module file is an integral part of a RoboCell project. Opening or saving a project opens or saves the RoboCell program, robot positions and graphic module data as one entity.

You can open a new RoboCell project and then import a virtual cell from an existing project or a cell created using CellSetup (File | Import 3D Model).

Only one CellSetup file/window can be opened at a time.



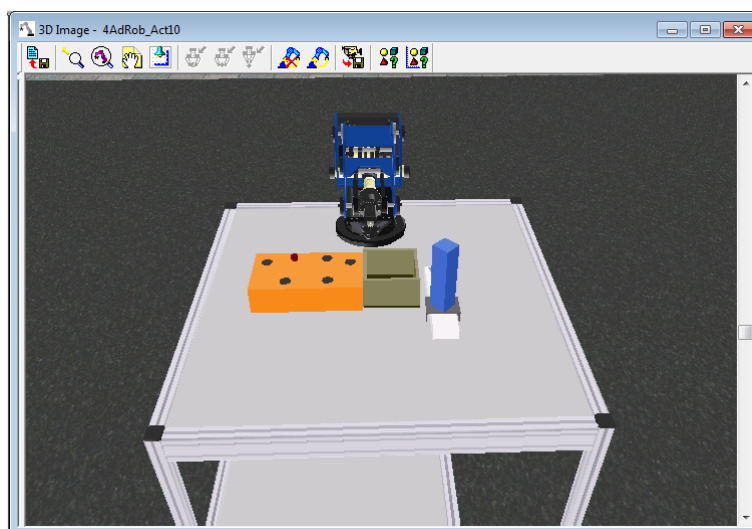





When you open a project which already contains a workcell, the graphic display module window is displayed.



The 3D image portrays the robotic workcell and all its components. Using the graphic display tools described in Chapter 3, you can manipulate the image and view it from different angles by controlling the angle and position of the virtual “camera” that monitors the workcell. Other tools enable you to see other data related to the cell (such as object name, position or the number of part in a feeder).

5.2.1. 3D Image Menu & Toolbar

All graphic display tools are accessible from the 3D Image Menu. Frequently used tools can also be accessed from the toolbar.

3D Image Menu and Toolbar		
Icon	Option	Description
	Reset 3D Model	This options returns the workcell image to the initial setting and position (saved in CellSetup). This tool is useful when you want to initialize the workcell before re-running a program.
	Top View	Resets camera position to the top center point of the cell
	Drag Image	This option activates the drag mode in order to drag the entire image to a new position. Using the cursor, point and click anywhere on the image and drag it to its new position. The drag mode remains in effect until you select another option or press [Esc] .
	Camera Sub-options:	The 3D image window displays the output of a virtual camera that is fitted in the workcell. Manipulating the camera determines how the image is displayed in the window.
	Redirect Camera	Selects the point that is always in the center of the screen (while rotating, zooming and changing the camera’s angle). The Redirect Camera mode remains in effect until you select another option or press [Esc] .
	Follow me Camera	This option enables you to follow the movement of any object (robot gripper, certain object, etc.) when the workcell is running. To select the point, choose a point on a moving object (part of the robot or an object). Press [Esc] to exit Redirect Camera.
	Save Camera Position	This option saves the current camera position. Only one camera position can be saved. Saving a new position overwrites the previously saved position.
	Restore Camera Position	Restores the position recorded using Save Camera Position
	Labels Sub-options:	
	Object Names	Shows/hides Object Name labels
	Object Positions	Shows/hides Object Position labels

3D Image Menu and Toolbar		
Icon	Option	Description
		The label displays the X and Y coordinates of the object position that is relative to the coordinates of the 3D model.
	Object Positions in Robot Coordinates	Shows/hides Object Position Robot Coordinates The object position displayed is relative to the robot coordinates. The robot coordinates may be different from cell coordinates if: <ul style="list-style-type: none"> The robot was moved after initial setting (in CellSetup). The robot is equipped with LSB. When the robot moves, the position of objects relative to the robot changes.
	Number Parts in Feeder	Shows/hides a label that displays the number of remaining objects in a feeder
	Send Robot Sub-options	Select Options Simulation to enable the Send Robot options.
	Send Robot to Object	This option sends the robot to the selected object. Make sure the gripper is open before sending the robot to the object. This option is useful for defining a robot pick position.
	Send Robot to Point	This option sends the robot to the selected point. The option is useful for defining a robot place position.
	Send Robot to Above Point	Sends the robot to a point above the selected point on the table Default: point 100 mm above the selected point.
	Options for Send Robot	Opens the Send Robot Options dialog box enabling you to define the vertical offset values and the gripper's orientation when Send Robot commands are executed

The Send Robot Options dialog box is shown here:

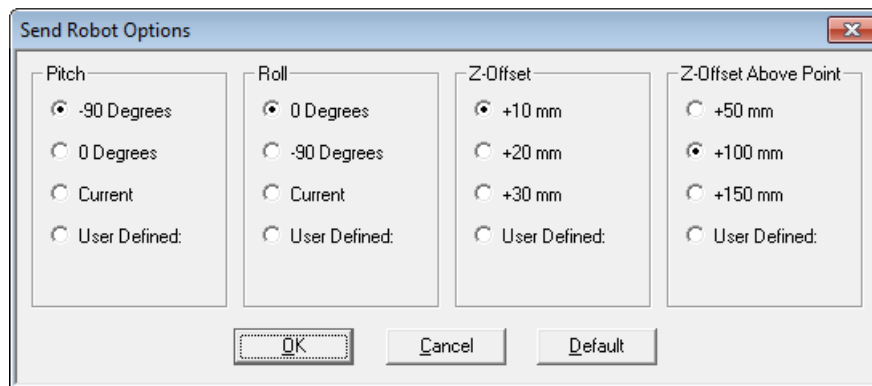

The settings remain in effect for all subsequent Send Robot commands. When the gun is selected, default gun settings are used automatically; user-defined settings are ignored.



By default, the robot moves to an object or point with the gripper perpendicular (-90) to the table and with no (0) rotation.

You can also use the SCORBASE Manual Movement dialog box (see 6.1 Robot Manual Manipulation on page 51) to adjust the orientation (pitch and roll) of the gripper. You can then select the option **Use Current** to maintain the gripper's orientation during subsequent Send Robot commands.

The Z-offset value is used by the Send Robot to Object and Send Robot to Point commands. The Z-offset Above Point value is used by the Send Robot Above Point command.

Robot Options	
Option	Description
Show Path	When selected, a line showing the gripper path is drawn on the screen as the robot moves. The distance between the points is proportional to the TCP speed.
Clear Path	Clears the robot path that was drawn using Show Path
Show Origin	This option shows the origin of the cell at floor level (under the center of the robot's base) as a red cross marked with X and Y axes. The positions of all objects are defined as relative to this point of origin. When manipulating the graphic display, the cross may disappear momentarily. This option is the same as Scene Origin described in chapter 4 CellSetup on page 11.
Show Robot Work Envelope	Displays the span of the robot's working range, allowing you to see whether objects are within the reach of the robot. This option is the same as the Show Envelope option of the Robot Properties.
Welding Settings	This option opens the Welding Setting dialog box, which enables definition of the welding parameters.

6. Cell Operation

Operating and programming the robot in RoboCell is similar to working with a hardware robot. Graphic display features and automatic operations, such as Cell Reset and Send Robot commands, enable quick and accurate programming.

6.1. ROBOT MANUAL MANIPULATION

The SCORBASE Manual Movement dialog box allows you to manipulate the robot and peripheral axes in the simulated cell in the same way that it provides control of an actual robotic system.

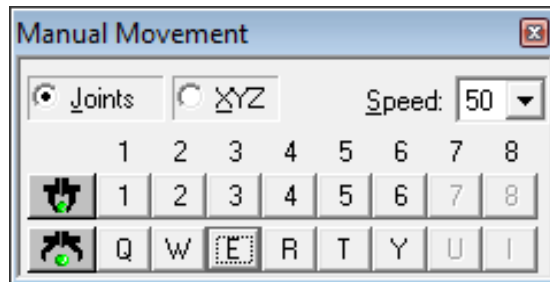

To move the virtual robot axes:

- Click the keys on the Manual Movement dialog box, or
- Press the corresponding keys on the keyboard.

Movement of an axis continues as long as the button or key is pressed, or until a software or hardware limit is reached.

Use the Open Gripper and Close Gripper buttons to control the gripper.

6.2. MACHINE OPERATION

You can operate the Mill or Lathe directly from the Digital Output dialog box, or with program commands (see 6.7 Program Execution on page 55). A program continues to run after the machine begins to operate.

Be sure to close the chuck on the Mill or Lathe before you open the Robot gripper to release it. A part placed in the Lathe drops to the bottom unless the chuck is closed before opening the robot gripper.

A part placed in the Mill may fall once the Mill cycle begins, if the chuck is not closed before starting the cycle.

The Mill and Lathe work only if the door is closed.

6.3. SEND ROBOT COMMANDS

Send Robot commands can often be used instead of the SCORBASE Manual Movement dialog box. Commonly, however, the Manual Movement dialog box is used to adjust the robot's position after using a Send Robot command.



When SCORBASE is operating online with an actual robotic cell, the Send Robot commands and options are disabled.

When using the Send Robot commands, be aware of certain characteristics of the following objects:

Send Robot Commands	
Object	Description
Feeders	<p>Click the part in the feeder (and not the feeder itself), to select it as the target position for the Send Robot to Object command.</p> <p>To pick up a part from the feeder, select a pitch of 0° and a roll of (-90°) in the Send Robot Options dialog box.</p>
Lathe	<p>Each of the four clamps in the chuck can be a target object. You cannot use the Send Robot to Object command to place an object in the lathe. The object must be placed in the chuck manually.</p> <p>Only cylinders can be placed in the chuck. Use the Manual Movement dialog box to position the cylinder exactly.</p>
Mill	<p>Click the jig in the mill to select it as the target for the Send Robot to Point command. Use the grid on the jig to help place the object.</p>
Table	<p>Use the Send Robot to Point (not Send Robot to Object) command and select a specific target point on the table. The robot moves to that position with the offset defined in the Options for Send Robot dialog box.</p>
Template	<p>Although it is regarded as one object, the template is comprised of two objects, the tray and the handle, either of which can be a target object. The template has only one position, defined by the center of the tray.</p> <p>Use Z-offset 35 mm to send the robot to the template tray.</p> <p>Use Z-offset 0 mm (user-defined) to send the robot to the template handle.</p>

6.4. GRIPPER

The Gripper is a dynamic and important part of your robot. The features of the gripper are covered in the sections below.

6.4.1. Grasping Objects

The robot gripper in RoboCell grasps objects only as a result of Close Gripper commands.

When the gripper closes on an object, the object is pushed into the center of gripper.

In addition, cubes and horizontal cylinders are rotated into alignment with the gripper jaws, provided the rotation offset does not exceed 35°. When the offset is about 45°, the gripper simply grasps the object at its corners.

Since objects are rotated around their center, a long object that is grasped far from its center must be aligned with the gripper as much as possible before the gripper is closed.

6.4.2. Releasing Objects

RoboCell operates in a gravitational field. Objects that are released from the gripper fall to the highest surface below them.

If more than half of an object's base rests on a surface, the object remains on the surface. Otherwise it falls onto the surface below.

Objects can be picked up and released at any rotation.

6.5. IMPACT DETECTION

RoboCell checks for the following impact conditions:

- The tip of the gripper hits an object or the robot itself
- The edge of the gripper motor (mounted on top of the gripper) hits an object or the robot itself
- An object held by the gripper hits another object or the robot

RoboCell's impact error message is the same one sent by SCORBASE when an actual robot cannot reach a target position. Since there are no mechanical (motor) or electrical (encoder) failures in simulation, you can assume simply that the gripper or an object held by the gripper has collided with the robot or another object.

The Graphic Display status line indicates the object on which the impact has occurred.

In response to the impact error message, click **OK** to resume Control On. Then move the robot away from the impact condition. If a Send Robot command caused the impact, the robot resumes movement from the position that preceded the Send Robot command.

When SCORBASE is operating online with an actual robotic cell, SCORBASE controls impact detection and response, and Cell Simulation's impact detection function is disabled.

6.6. DEFINING POSITIONS

RoboCell provides the methods described below for defining robot positions. A position is identified by its assigned number.

6.6.1. Recording Position #1

To record position #1:

1. Use the SCORBASE Manual Movement dialog box to manipulate the virtual robot in the same manner in which you would manipulate an actual robot.
2. When the position is reached, type a number in the position number field in the Teach Position (Simple) dialog box.
3. Click **Record**.

If the position number has been used previously, the new position overwrites the previous position data.

6.6.2. Recording Position #2

To record position #2:

1. To send a robot to a required position, use the Send Robot to Object/Position/Above Position tools.
2. If needed, use the Manual Movement dialog box for fine-tuning.
3. When the position is reached, type a number in the position number field in the Teach Position (Simple) dialog box.
4. Click **Record**.

If the position number has been used previously, the new position overwrites the previous position data.

6.6.3. Teaching Position

1. In the Graphic Display window, select **View | Object Positions** to view the X and Y coordinates of an object.
2. Zoom in on the object or point whose coordinates you want to record.
3. In the Teach Position (Simple) window, click the **Expand** button. The Teach Positions window is expanded.

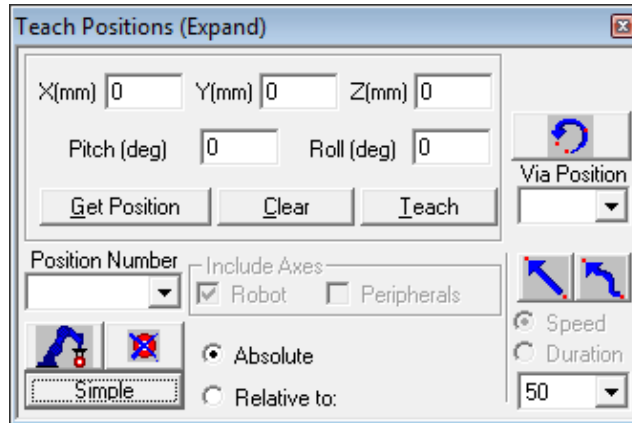

4. Type the position coordinates in the X, Y, Z, Pitch, and Roll fields.
5. Enter a position number in the **Position Number** field.
6. Click **Teach**.

Note: If you click **Record Position**, the current robot position is recorded (and not the position defined by the coordinates you entered in the X, Y, Z, Pitch, and Roll fields).

If the position number has been used previously, the new position overwrites the previous position data.

6.6.4. Fine-tuning a Position

To modify existing positions:

1. In the Teach Position (Simple) window, click the **Expand** button. The Teach Positions window is expanded.
2. Select the position you want to modify in the **Position Number** field.
3. Click **Get Position**. The position data is displayed in the X, Y, Z, Pitch, and Roll fields.
4. Modify the required coordinate.
5. Click **Teach** to overwrite the previous position.

6.7. PROGRAM EXECUTION

Executing programs in RoboCell is the same as executing programs when using an actual robotic system.



Since different cell configurations can be loaded and changed in RoboCell, keep in mind that positions and programs are not loaded together with their workcell.

To use a workcell with its positions for a new project:

- In **File | Save as**, save the project with the workcell and positions under a different name.
- Delete the program and write a new one (the positions and the cell remain unchanged).

7. Welding Features

7.1. INTRODUCING WELDING FEATURES

RoboCell welding features contain 3D-solid modeling robotic welding options for teaching modern techniques of arc welding.

The software features the following:

- Welding of multiple parts both online and in simulation
- Accurate display and manipulation of welded parts both online and in simulation
- Single-command character generator that calculates and teaches all positions required for producing any text string
- Predefined welding cells and fully functional demonstration programs for simulated execution.

A typical welding cell is shown below.

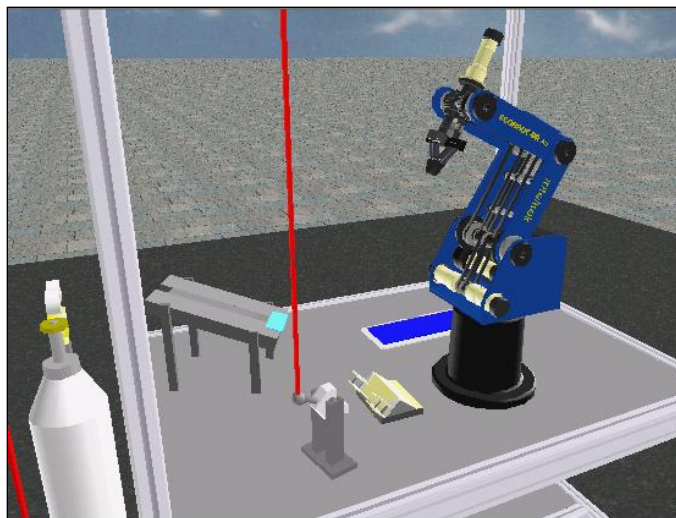

Welding features enable several types of welding processes: T-joint welds, butt welds and the welding of letters and numerals.

- **T-joint weld:** A T-joint weld is shown below. It is in the shape of a letter T.

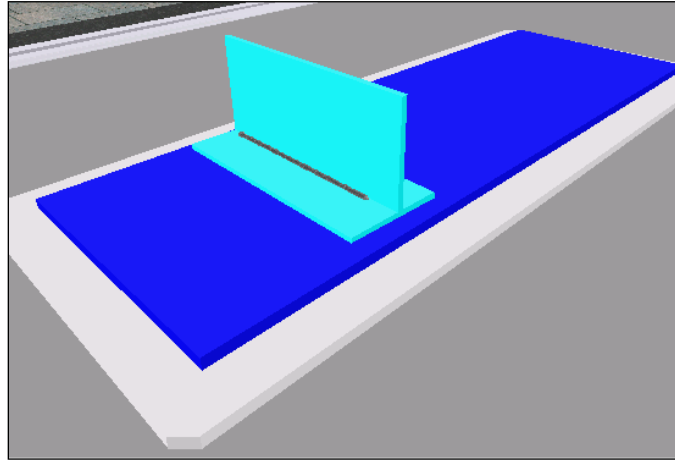

- **Butt weld:** Weld in which the pieces are welded side-by-side.

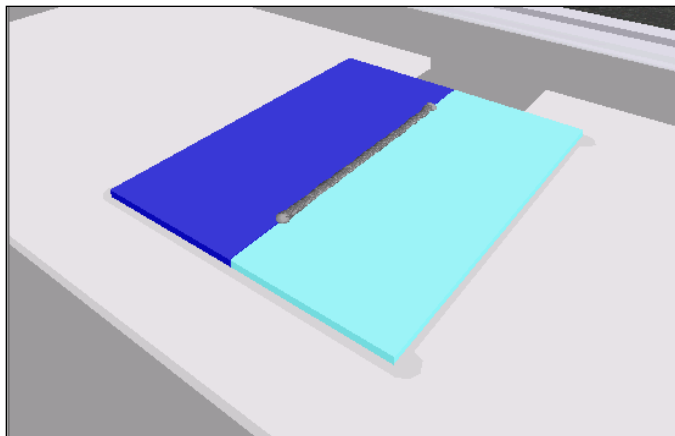

- **Letters and numerals:** A gun is used to weld letters or numerals on a large metal plate placed on the butt jig.

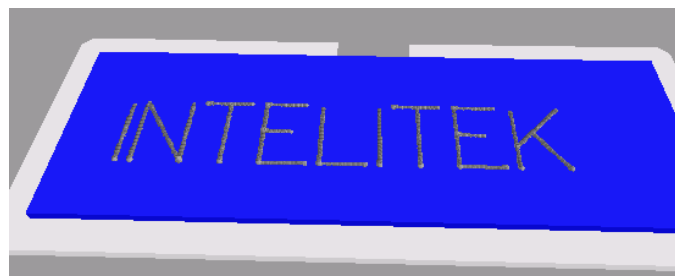

The workcell allows fully automatic T-joint welding operations:

- Retrieval of metal plates from gravity feeder
- Loading of parts into T-joint jig
- Retrieval of MIG gun

- Arc welding
- Returning of gun
- Unloading of weld from jig for cooling

Welding of a butt joint or of numerals/letters is performed similarly. However, for these processes, the metal sheets must be placed in the jig during the cell setup stage. The robot's work envelope does not allow it to place and remove parts from this jig.

7.2. WELDING TABLE CONFIGURATION

The welding table should be placed in the cell just before or after the robot (the first object) has been placed. Most welding objects are automatically placed at the correct default welding table height, even if they are not placed directly on the welding table.

The Welding Table Configuration dialog box is shown here:

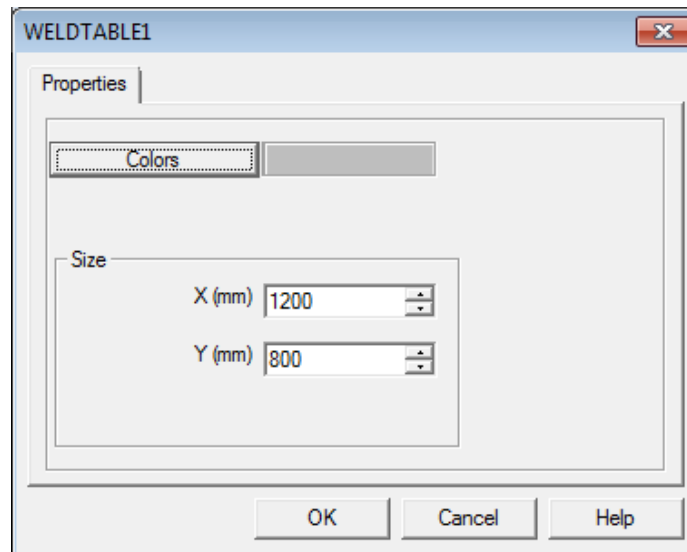

A table summarizing the options of the Welding Table Configuration dialog box is shown here:

Welding Table Configuration	
Colors	<p>Opens the color pallet to define the color of the welding table. The booth poles remain default gray.</p> <p>To distinguish the table, use a color that is different from the colors used for the floor and background.</p>
X (mm); Y (mm)	<p>Defines the length and width of the table in millimeters. X and Y dimensions are always in accordance with the X and Y dimensions of the cell. (Use the Show Cell Origin option to display the X and Y origin of the cell.)</p> <p>You can accept or change the default dimensions of 1200 x 800 mm.</p>

7.3. WELDING MACHINE PROPERTIES

The Welding machine supplies the electric energy required for the welding process to the welding gun. As such, you cannot save a cell containing *only* a welding gun or *only* a welding machine. Neither or both must be present in order to save the cell.

To open the welding machine properties window, perform one of the following:

- Select **3D Image | Welding Setting** from the RoboCell main menu.

Note: The Welding Setting option is only enabled if you have defined a welding machine and a welding gun in the cell.

- Double click the welding machine image in the 3D window.

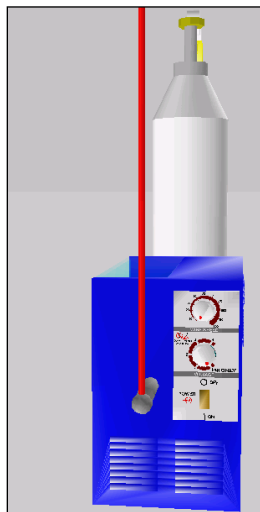

The Welding Machine Properties menu contains the following additional option:

Additional Welding Option	
Welding Settings	Opens the Welding Settings dialog box which enables definition of the following weld parameters: <ul style="list-style-type: none">• Voltage Tap• Wire Diameter• Wire Speed• Shielding Gas

The Welding Settings dialog box is shown here:

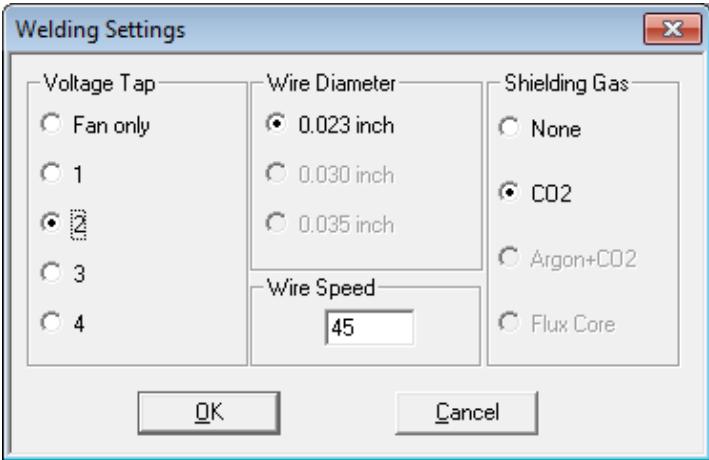

The Welding Settings dialog box options are described in this table:

Welding Settings	
Voltage Tap	<p>Sets welding machine voltage output supplied to the welding gun, an important variable in determining the quality and appearance of a weld. The voltage tap value is a reference number (2 in the image above does not indicate a voltage value).</p> <p>The voltage tap should be set according to several factors, such as robot speed, wire speed and metal thickness.</p>
Wire Diameter	<p>Sets diameter of the welding wire being fed to the MIG welding gun. This cannot be changed.</p>
Wire Speed	<p>Sets speed at which the wire is fed to the MIG welding gun. This is also known as feed rate.</p> <p>The wire speed setting is essentially a reference value to the controller built into the welder. Valid values: 10 - 100.</p> <p>The wire speed is automatically regulated by the welder for optimal performance and does not need manual input. The welder determines the feed rate setting by weighing three factors: type of shielding gas, metal thickness and wire diameter.</p>
Shielding Gas	<p>This option sets the type of gas for shielding the weld from oxidation, which causes rust and poor joining of the welded pieces. The system only works with CO2 gas.</p>

The default parameters are set according to the Millermatic recommended settings (see the Millermatic User's Manual).

Some parameters are interrelated. For example, changing the voltage tap causes the wire speed default to change automatically. Note that the wire speed can also be changed independently of the voltage tap.

Welding settings can also be changed by the user when working within the Graphic Display window. The settings remain in effect for all subsequent simulated welds.

Note: Changes in this dialog box do not affect the actual Millermatic welder settings.

This dialog box can also be accessed by double-clicking the welding machine knobs. Note that parameter changes are reflected in the knobs' positions.

Additional Welding Settings	
Controller Output Number for Welding Machine	<p>The welding machine operation is controlled using a controller output. After placing the welding machine (in CellSetup) you should assign a free controller output for controlling the welding machine.</p>

7.4. WELDING TOOLS

The welding tools available in CellSetup are described below.

7.4.1. Gun Stand

The gun stand does not require the user to define any additional configurations or properties. The user need only place it in an accessible position on the welding table.

CellSetup draws the cable that connects the welding machine to the gun.

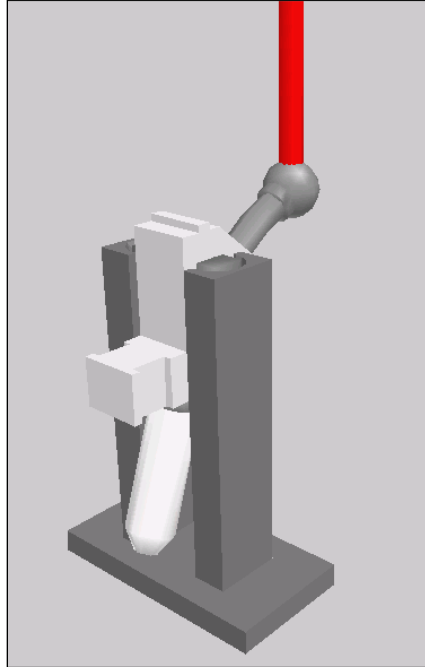

You cannot save a cell containing *only* a welding gun or *only* a welder. Neither or both must be present in order to save the cell.

7.4.2. Welding Jig A (T-Joint)

Welding Jig A is a device used to securely hold two materials being welded together in a T-joint. This jig does not require the user to define any additional configurations or properties. The user need only place it in a position on the welding table in which the robot can access the jig from both ends to place and remove parts.

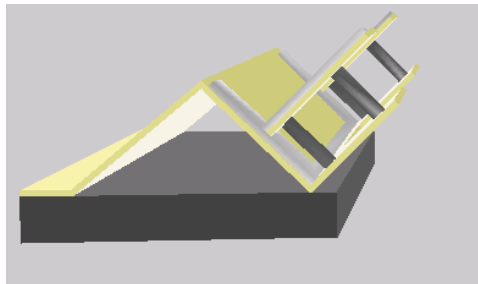

7.4.3. Welding Jig B

Welding Jig B can be used for various types of welds. The grooved area in the center of the jig can be used to securely hold two metal sheets side-by-side to create a butt weld. The jig can also be used to hold the larger nameplates used with the SCORBASE Write command. For more information, see the SCORBASE User Manual.

Welding Jig B (shown below) does not require the user to define any additional configurations or properties. You only need to place it in an accessible position on the welding table.

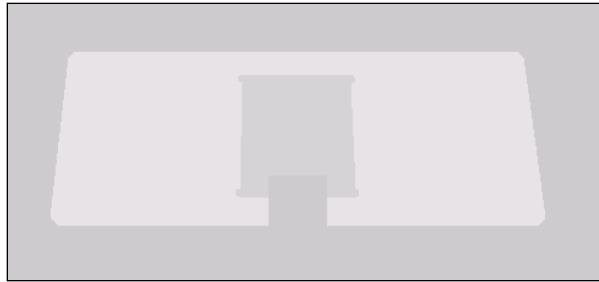

7.5. WELDING MATERIALS

There are a number of available welding materials in RoboCell. These materials are covered in the following sections.

7.5.1. Plate

Plate refers to the welding metal plates which are used with Welding Jig A. When you select **Plate**, this dialog box is displayed:

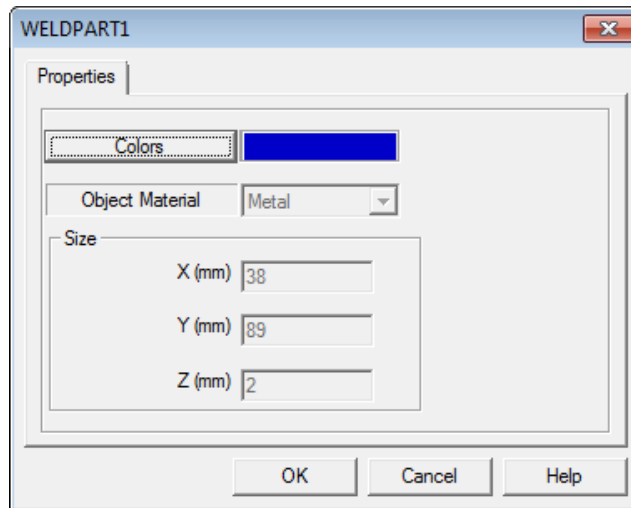

The options of this dialog box are described here:

Plate Configuration	
Option	Description
Colors	You can define the color of the plate to which the sensor is sensitive. The default color is blue. To change the color, click Colors. This opens a color palette from which you can select the required color. Make sure the color you select is compatible with the sensor's detection definition.
Size	The default dimensions of the plates are 38 x 2 x 89 mm. These are for display purposes only and cannot be changed.

7.5.2. Metal Cube

When you select **Metal Cube**, this dialog box is displayed:

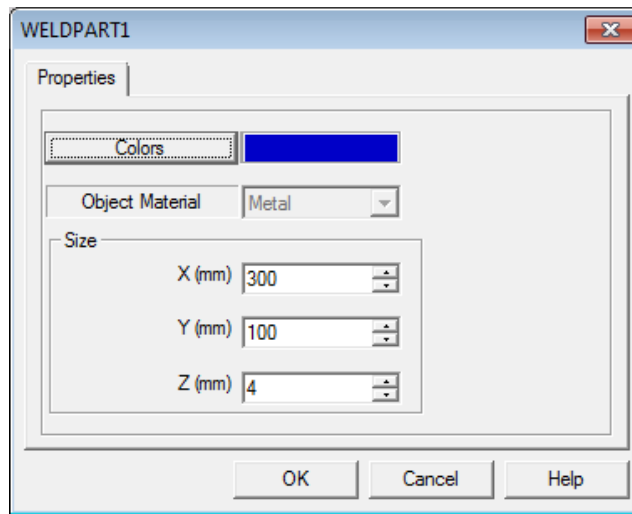

Features of the dialog box are described in the table below.

Metal Cube Configuration	
Option	Description
Colors	Define the color of the cube in the same way as described for the Plate.
Size	Any dimensions can be defined provided that the cubes are compatible with either welding Jig A or B.

7.6. ADDITIONAL WELDING FEATURES

The RoboCell's Graphic Display includes various additional welding features. These features are covered in the sections below.

7.6.1. Advanced Send Robot Commands

This section describes advanced positioning commands for the robot.

7.6.1.1. Recording Positions for Welding Jig A

Welding features enable easier recording of positions for Welding Jig A. To record the position for placing a part in the left side of the jig, use the **Send Robot to Object** option and click anywhere on the protruding parts of the jig (indicated by the number "1" in the image below). RoboCell automatically sends you to the correct position for placing the part. Note that this position is also used for removing the welded part from the jig.

To place parts in the right side of the jig, click any of the areas numbered "2" in the image below.

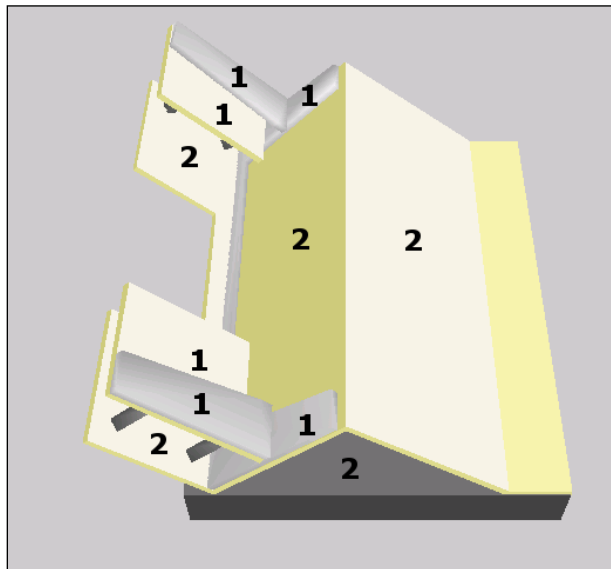

7.6.1.2. Recording Positions for Welding Gun

Welding features include a built-in feature to facilitate recording the pick position for the welding gun. To record the position for picking the gun, use the **Send Robot to Object** option and click the gripper adapter handle on the gun. RoboCell automatically sends you to the correct position for properly picking the gun.

7.6.2. Welding Booth Doors

The welding booth doors can be viewed or removed by double-clicking anywhere on the booth.

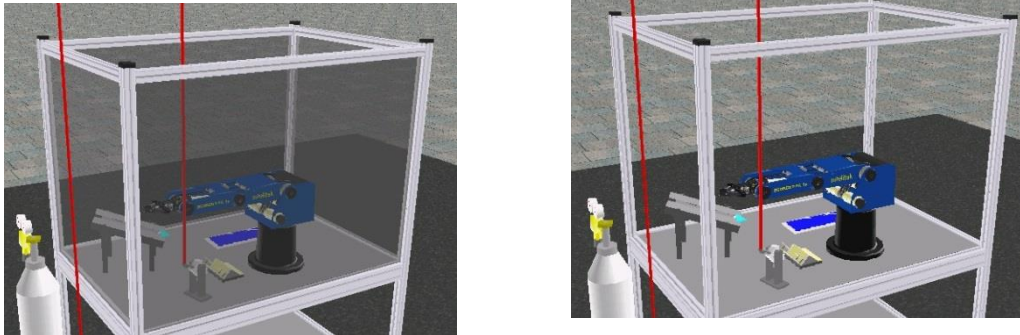

7.6.3. Welder

The welder has the following built-in features:

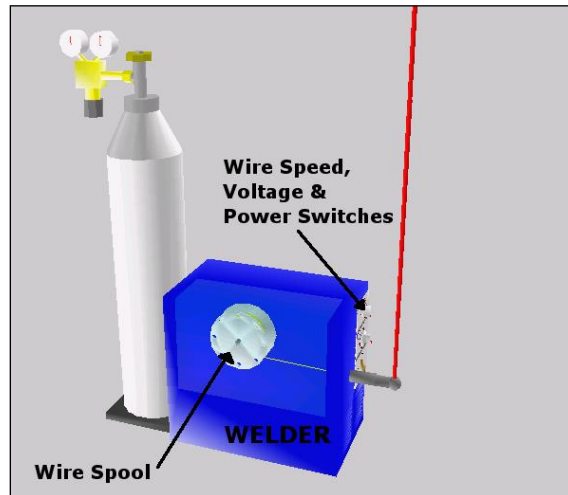

The built in weld features are summarized in this table.

Built in Welding Features	
Feature	Description
Wire Spool Motion	During the welding process, the wire spool turns just as it does in reality.
Wire Speed, Voltage and Power Switches	The knobs on the welder accurately reflect the welding settings defined via the Welding Settings dialog box. Double clicking any knob opens the dialog box.

7.6.4. Welding Parameters

Successful automated welding is often not the result of reliable technology, but of proper planning. Therefore, it is extremely important to work only with the optimal parameter settings defined by the manufacturer. The following welding parameters can be modified:

Welding Parameters	
Parameter	How to Change Parameter
Inert Gas Shield	From the Welding Settings dialog box, select either None or CO2 .
Voltage Tap	From the Welding Settings dialog box, select one of the reference numbers.
Wire Feed Rate	From the Welding Settings dialog box, select one of the reference numbers. The wire feed rate automatically changes when the voltage tap is changed.
Rate of Travel	To define the rate of travel (the speed of the robot and the welding gun in the welding procedure), use the Duration setting in the Go To Position dialog box. By changing the duration it takes to get from position A (weld start position) to B (weld end position), the robot's speed is changed – thus changing the speed at which it welds.
Distance of Electrode from Materials to be Welded	When recording the start/finish welding positions, you define this distance by defining the positions' Z value. Welding only occurs when the electrode of the welding gun is located at a proper distance above "weldable" material. This feature was built-in to enable more accurate recording of the start welding position. Once the software recognizes that welding is "allowed", the gun emits wire that creates a seam between the two materials. Welding does not occur in the following situations: <ul style="list-style-type: none"> • The electrode of the welding gun is too close or too far from the material. • The welding gun is located above a material that the software recognizes as "non-weldable".
Angle of electrode	When recording the start/finish weld positions, you define this angle by defining the positions' pitch.

7.7. WELDING PROCESS

RoboCell invites you to experience a realistic welding process. The process is covered in the following sections.

7.7.1. Welding Gun Operation

As welding occurs, sparks fly from the welding gun, as shown in this image.

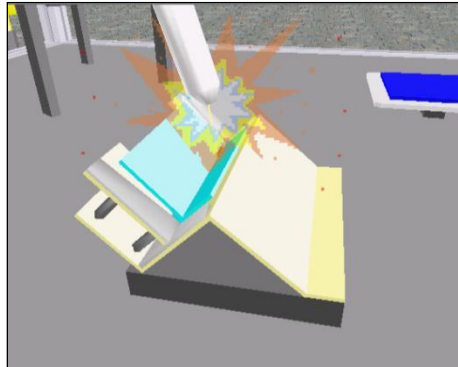

7.7.2. Weld Temperature

Changes in the temperature of the welding seam can also be seen by zooming in on it during and after the welding. Immediately after the welding, the seam is red and yellow – indicating that it is extremely hot. Slowly, it changes to a grayish color – indicating that it has cooled.

7.7.3. Welded Part

After the welding process is completed, RoboCell regards the two metal pieces as one. A completed T-joint welding process is shown in this image.

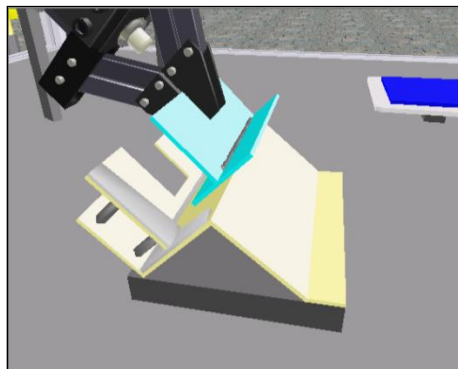

7.8. WELD ANALYSIS

RoboCell allows you to observe the quality of a weld at the end of the welding process. Depending on the welding settings used to create the weld, the appearances of welds may differ.

After welding two metals together, double-click the seam to open the Weld Properties window.

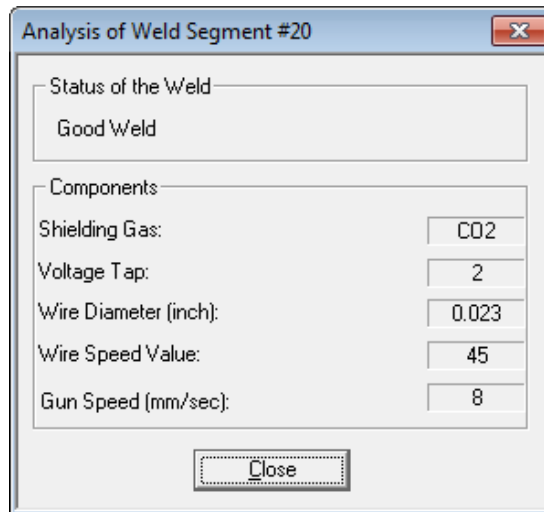

The window displays the following information:

- Status of the weld (e.g., good, bad)
- Whether shielding gas was used or not.
- Selected voltage tap value
- Wire diameter used
- Wire speed reference value that was used
- Speed of the welding gun

7.9. REPLICATING REAL AND SIMULATED CELLS

RoboCell's representation of robots and devices are based on actual dimensions and functions of SCORBOT equipment. Thus, programming performed in RoboCell can be used with an actual robotic installation.

7.9.1. From Simulation to Practice

Using CellSetup and Cell Simulation, create a cell, record all positions to be used by the SCORBASE program, write the SCORBASE program and verify program execution.

Then, to construct an actual robotic installation that duplicates the simulated cell:

1. Using CellSetup as a guide, place all objects and devices in their approximate locations.
2. To print a 3D Image, select **File | Print 3D Image**.
3. If necessary, hide labels and/or change the angle and zoom of the camera, and print several cell maps.
4. Consider your SCORBASE program and determine which of the recorded positions must be precise; for example, the point at which the robot takes an object from a feeder, or the point at which the robot places a part in a machine.

5. In SCORBASE On-Line mode, send the robot to these key positions. Adjust the location and orientation of the actual objects and devices (e.g., feeder, machine) according to the location of the gripper.

If you are unable to relocate the object or device, you can record the position coordinates additional times.

7.9.2. From Practice to Simulation

To create a simulated cell based on an actual installation, you need to know the exact location and orientation of every element in the cell.

If the cell layout is simple, this information can be obtained through a coordinate grid or a ruler. For a more complex cell layout, you may need a technical drawing (e.g., AutoCAD) which shows the center point and orientation of all objects.

All measurements should be made with both the robot and the cell at the same point of origin and with the same orientation.

8. Sample RoboCell Projects

Your RoboCell package contains a number of sample projects to help familiarize you with the capabilities of RoboCell. These are accessible by means of the File Open command. Press **Ctrl + O** on your keyboard, select **Open Project** from the File menu, or click the Open icon in the toolbar. You are then shown a listing of all the *.WS files in the following default installation subdirectory:

C:\Intelitek\RoboCell\Projects\ER 4u

8.1. 3D PROJECT DESCRIPTIONS

This section provides a description of the projects that are installed by default together with RoboCell.

ER4Cell1

Builds two towers, one of cylinders and one of rectangular blocks. This demonstrates the use of numbered positions.

ER4Cell2

Builds two towers from parts supplied by parts feeders. This demonstrates the use of named variables for positions.

ER4Cell3

Part sorting. This demonstrates the control of inputs and outputs.

ER4CellCNC1

Order cylinders and process parts. This demonstrates complex PICK movements and program control using IF statements.

ER4CellCNC2

This demonstrates visual representations of the path taken by the TCP (Tool Center Point) using the Intelitek ProLight lathe and mill.

Butt Joint

Picks up welding tool to weld two parts in a butt joint

Excel_EX1

This demonstrates the use of VBScript to transfer values from SCORBASE into Excel spreadsheets.

Intelitek

This demonstrates use of the SCORBASE "Write" command.

MICROCIM

Simulation of an OpenCIM device driver interface

New Project

Empty project

Polygon



This demonstrates the use of VBScript to transfer values from user input to SCORBASE and make floating-point calculation available to SCORBASE.

RunProgram1

This demonstrates multitasking implementation using the Run Subroutine command.

Script Demo

This demonstrates the interaction between SCORBASE and VBScript.

Serial Port

This demonstrates using RoboCell to send text messages via serial communications port.

Tjoint

This demonstrates complex pick & place movements and control of welding tool.

9. Troubleshooting

This table covers problems that you may encounter when working in RoboCell.

Troubleshooting in RoboCell	
Problem	Solution
The installation is unsuccessful.	Make sure all applications, including anti-virus monitors and network drivers, are closed. Then try installing the software again.
The program does not respond correctly.	There may be a message box hidden behind the application window. Minimize the application windows to check for messages or prompts.
The robot cannot be dragged to another position.	By default, the robot is placed at the cell's point of origin to simplify the teaching of positions. The robot's position can be changed only by means of its Properties menu.
The screen layout is jumbled or crowded.	Select View Simulation & Teach or View Simulation & Run to reset the screen layout. You can also select Options Load User Screen to reset a screen layout that you set and saved previously.
The peripheral axes do not move in RoboCell.	When SCORBASE is operating on-line, the peripheral settings defined in the CellSetup file are not loaded; the peripheral setup defined in SCORBASE is retained. Simulated peripheral axes that do not match the SCORBASE definitions do not respond to SCORBASE commands in the Graphic Display.